



160SP (39225 Inch/39226 Metric)

Rivet Nut setting Tool (Spin/Pull)

Instructions & Parts List



This is our most powerful air/hydraulic rivet nut setting tool. This spin-pull tool automatically threads the fastener onto the mandrel. Press and hold the trigger just once and the fastener is installed. It will automatically spin out of the Rivet Nut completing installation. Located at the bottom of the tool, the 160-SP features a fully adjustable stroke length to suit any grip range and a swivel air inlet for increased mobility. No complicated tear down is required to adjust the stroke or to change thread sizes, both adjustments are completed outside the tool. The 160-SP is capable of Rivet-Nut sizes 6-32" through 1/2-13" and 4mm through 12mm.

Weight: 6 lbs.

CAUTION:

ALWAYS WEAR SAFETY GLASSES WHEN OPERATING TOOL

**Arconic
Fastening
Systems and Rings**



1925 N MacArthur Dr. #200
Tracy, CA 95376
Customer Service: 800-826-2884
www.afsindustrial.com



Use only compressed air. Check airline for damage from humidity & contaminants. In order to protect the tool from premature wear, it is recommended a filter separator & regulator assembly be used. A lubricator is not necessary but a water separator is highly recommended. Normal working pressure is 85-95 PSI. Air connection thread size is ¼ - NPS (will work with ¼ - NPT air fitting with thread tape).

WARNING: Do not use air supply greater than recommended or tool might be become damaged or may burst. Do not use oxygen, combustible gases or bottled gases as a source for this tool. Gases could cause the tool to explode.

CAUTION:

ALWAYS WEAR SAFETY GLASSES WHEN OPERATING TOOL

Main Components

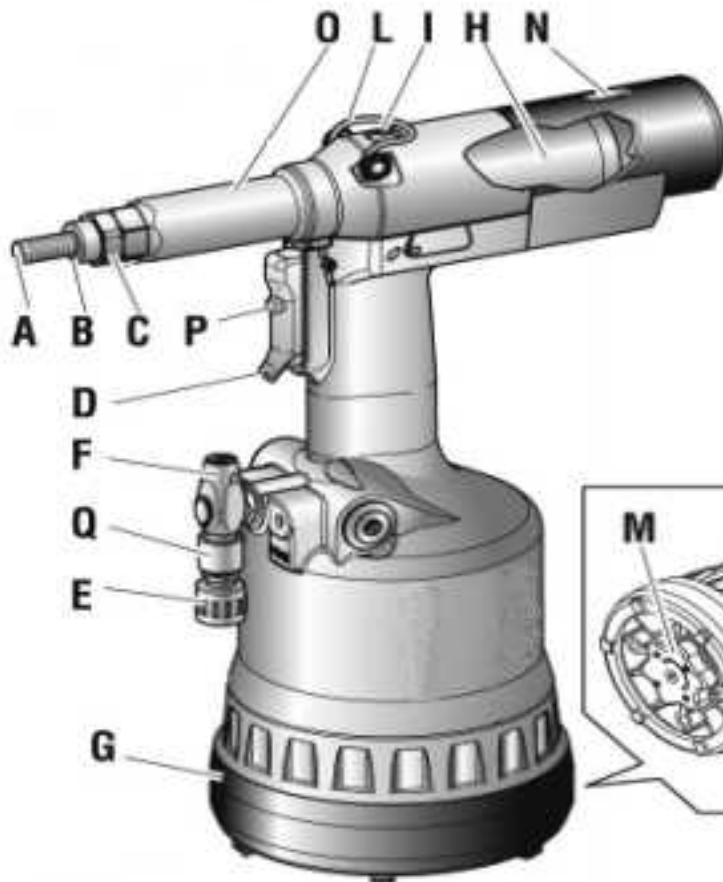

- A: Mandrel
- B: Nosepiece
- C: Nosepiece Lock Nut
- D: Trigger
- E: Air Connection (1/4-20 NPT female)
- F: Overpressure control Valve
- G: Protective Bottom
- H: Pneumatic Motor
- I: Fluid Plug
- L: Balancer Connection
- M: Stroke Adjusting Knob
- N: Stroke Indicator
- O: Head
- P: Forced Unscrewing Button (see pg. 6)
- Q: Air Entry Valve

ADDITION OF HYDRAULIC FLUID

The Hydraulic oil should be topped off after a long period of usage or when there is a power loss of the tool. Put the tool in a vertical position rotating the knob (M) towards the plus sign + up to the end of the stroke, and remove plug (I) by using a 4mm Allen wrench (supplied). After removal of plug (I) check the oil level in order to avoid overflowing. Next screw the oil container (T) supplied into the oil inlet hole until it is seated. While keeping the tool in the vertical position, connect the air line and pull trigger (D) and cycle the tool several times until air bubbles in the oil container (T) stop appearing in the oil container. This indicates that tool is filled of oil and is ready for use. Disconnect the air line and unscrew the oil container (T) from tool and replace plug (I) first checking to be sure the washer on plug is in position and not damaged. We recommend Mobil DTE-24 hydraulic fluid as a replacement. Do not use transmission fluids in this tool.

IMPORTANT: Make sure plug (I) is tightened at a torque corresponding to min. of 3.6 ft-lb and a max. of 5.9 ft-lb (5 Nm – 8 Nm)

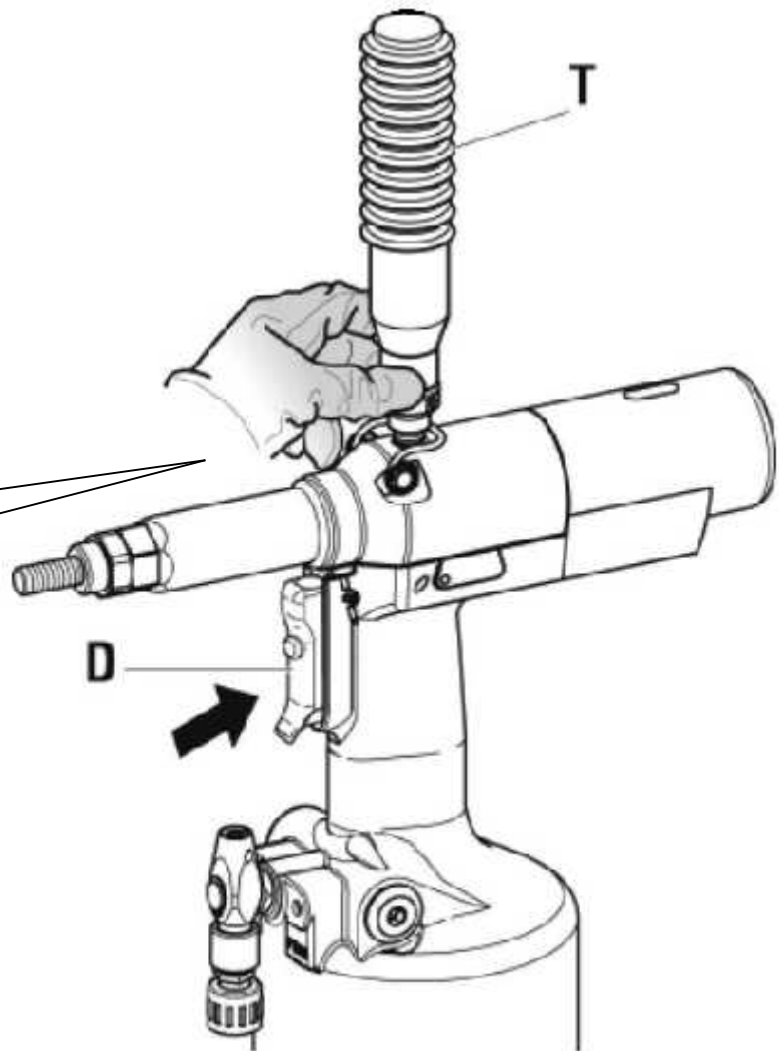
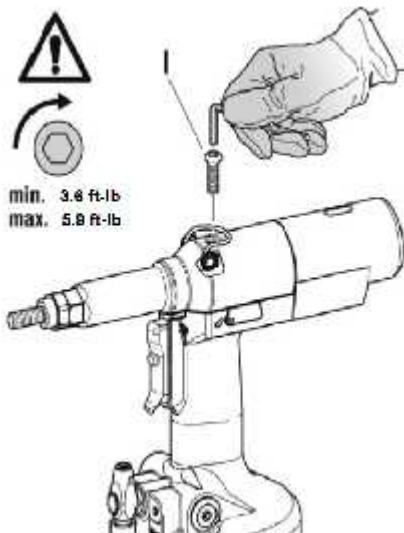

Changing Mandrel and Nosepiece

The tool is supplied with mandrels (A) and nosepieces (B) for setting Rivet Nuts. It will be necessary to change these depending on the Rivet Nut thread size. This can be done by loosening nosepiece lock nut using a 22mm wrench and remove nosepiece (B) and spacer (S) if it ranges from M4 – M6. With the same wrench remove the head (O) see f9. Push the mandrel in and pull up to remove - see f9. Reverse order to reassemble. **Ensure that tool is disconnected from air supply before changing these components.**

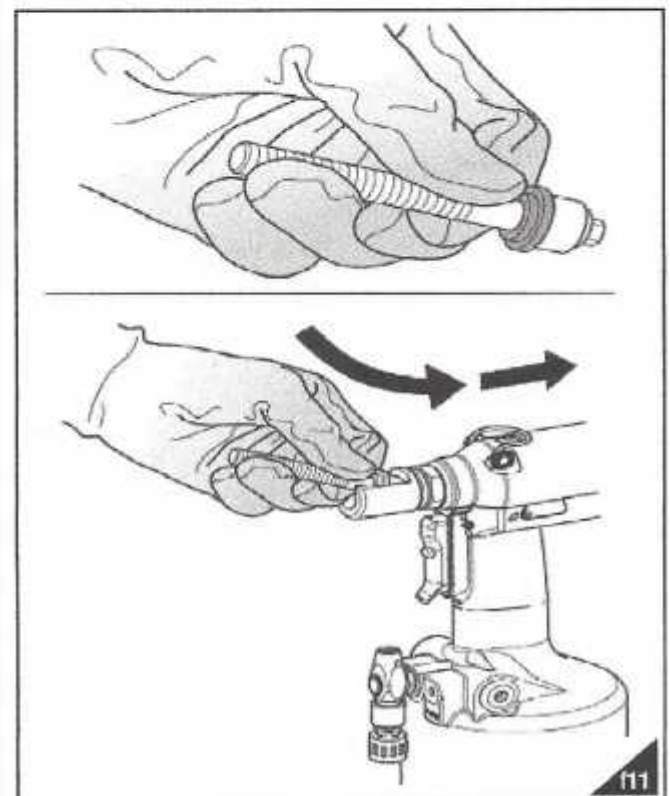
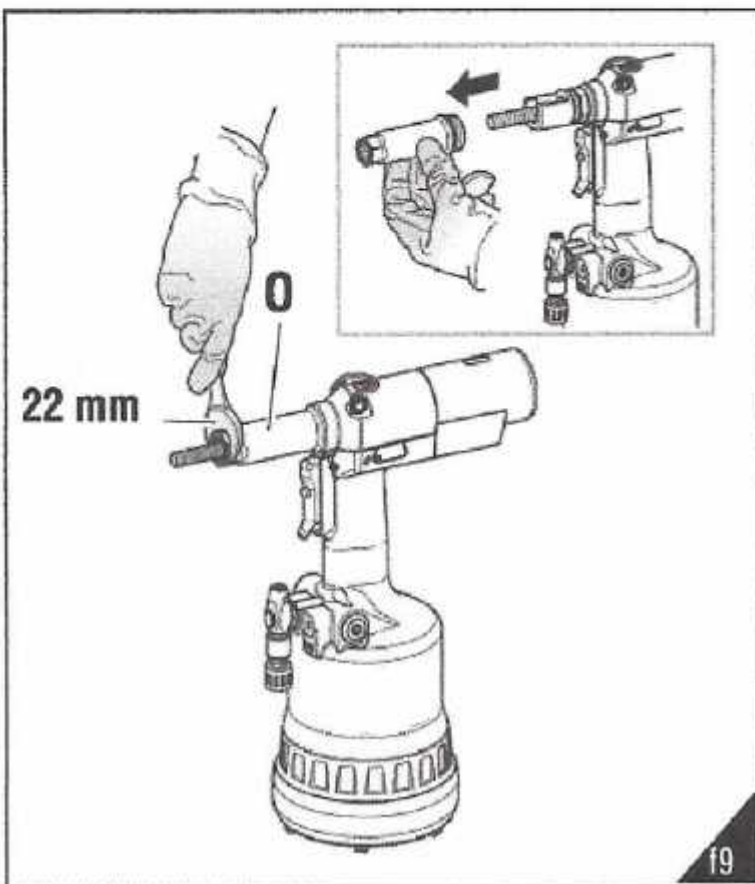
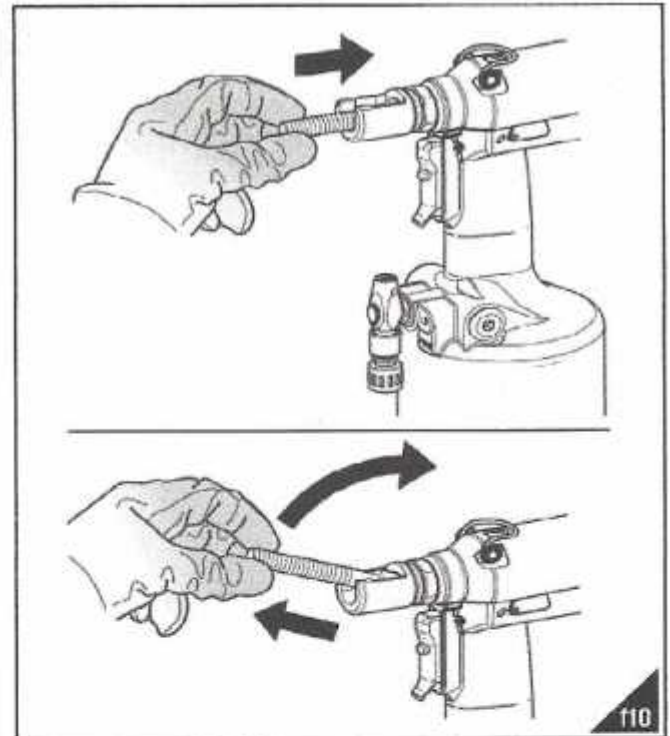
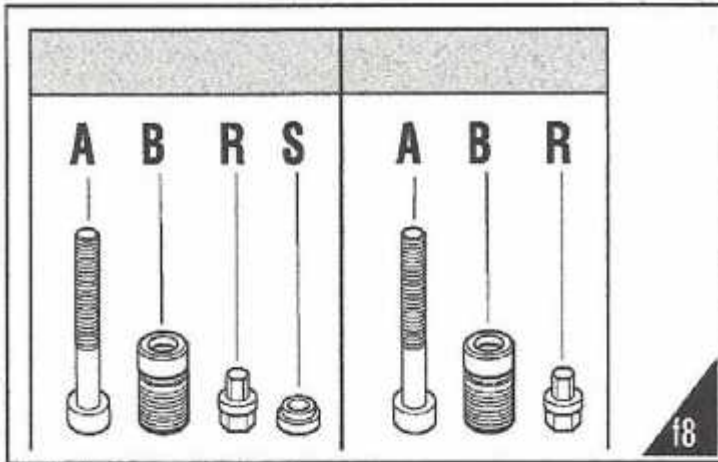

Adjusting Stroke Length (Preliminary Operations) [Page 5]

Before using the tool and after each change of thread size, the stroke should be adjusted according to the dimensions, type of insert and thickness of material rivet nut is to be installed in. The rotation of knob (M) in the direction indicated either decreases (-) or increases (+) the clamping force (h). Disconnect the tool from the air supply, adjust the stroke and then reconnect to air supply to check adjustments made.

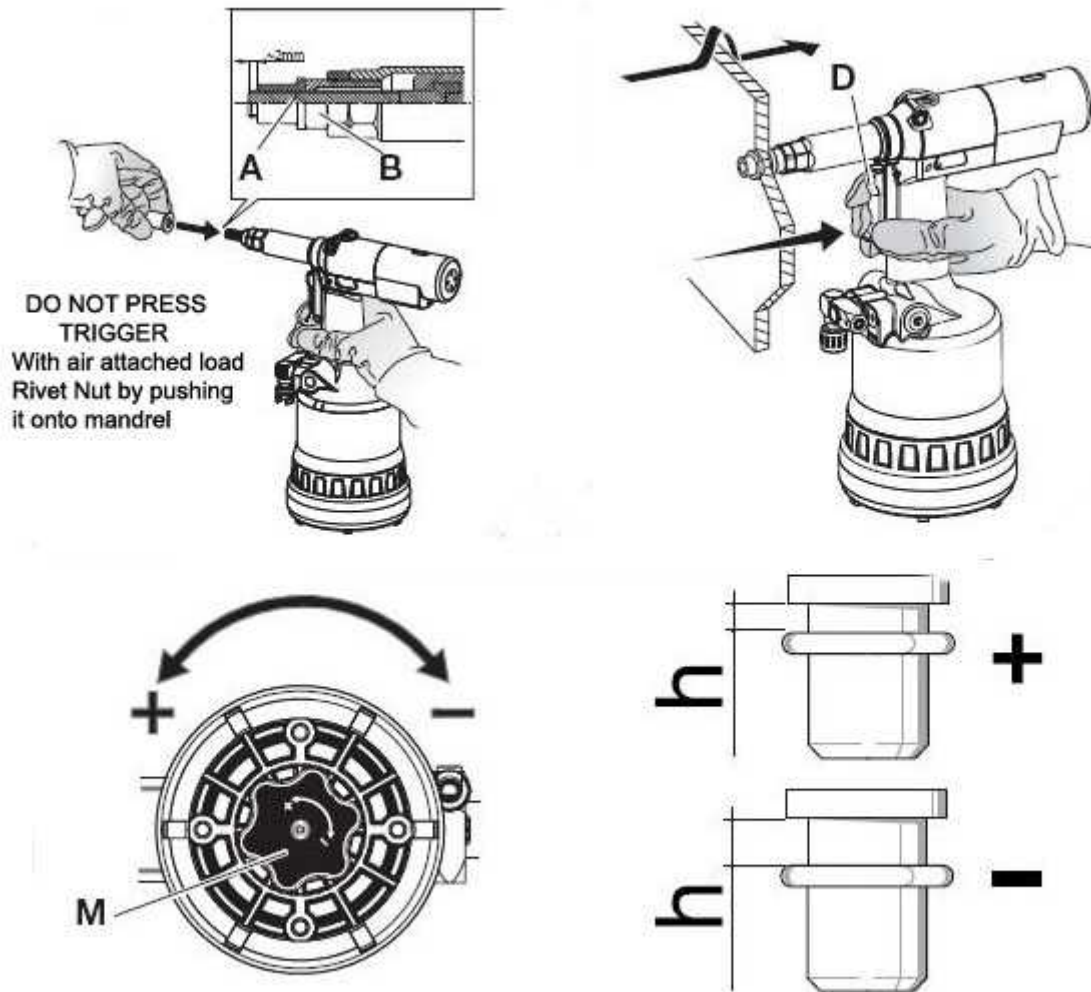

3 Simple steps to set Rivet-Nut

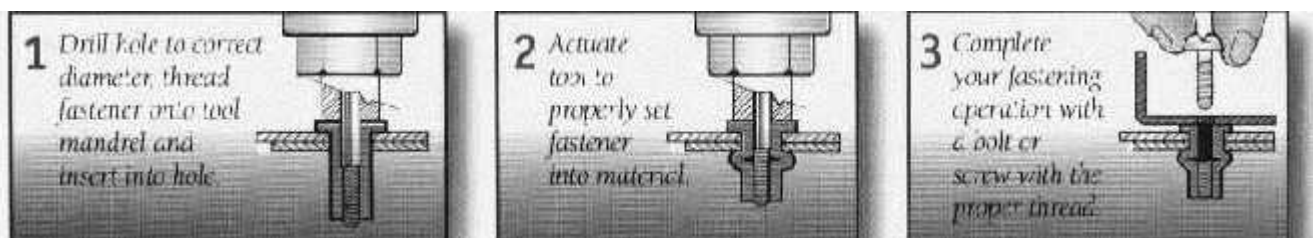

Any time it is necessary to unscrew the mandrel from the rivet nut (if the mandrel becomes stuck from too much installation stroke), push unscrewing button (P) to reverse the mandrel.

See diagram below

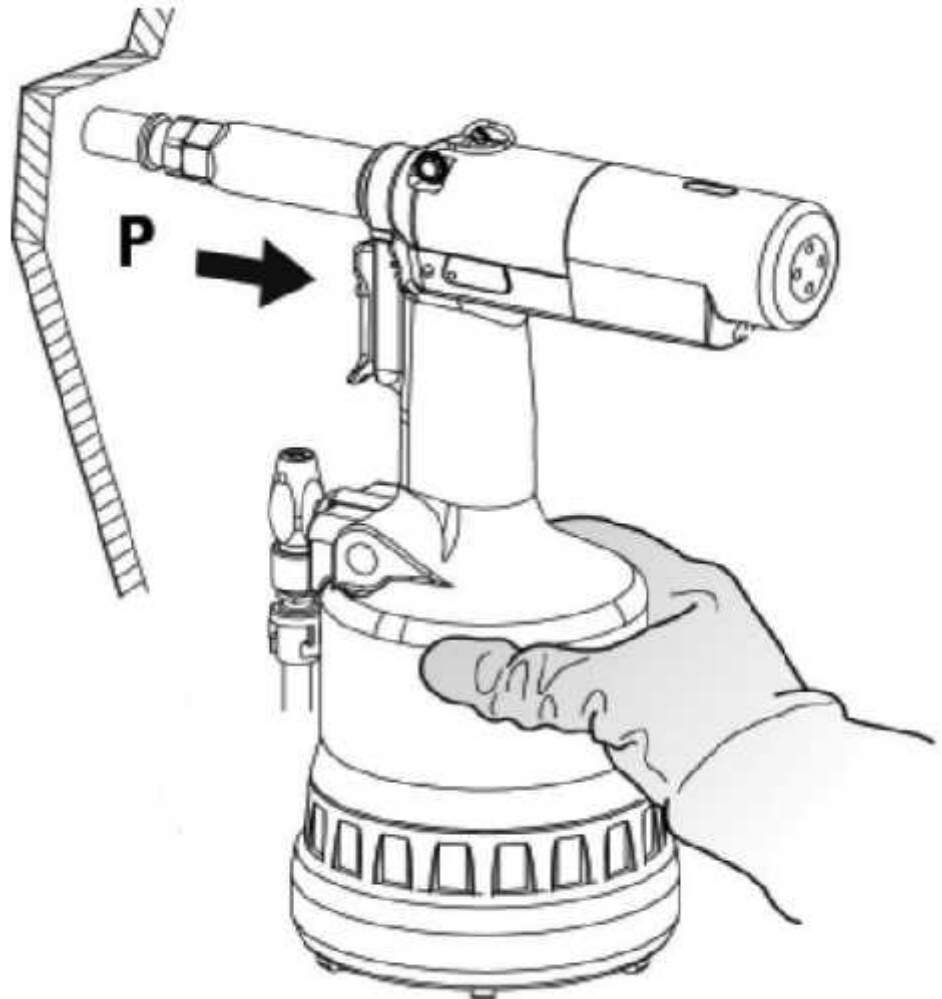
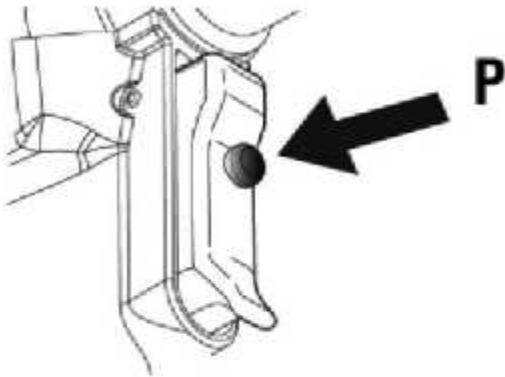

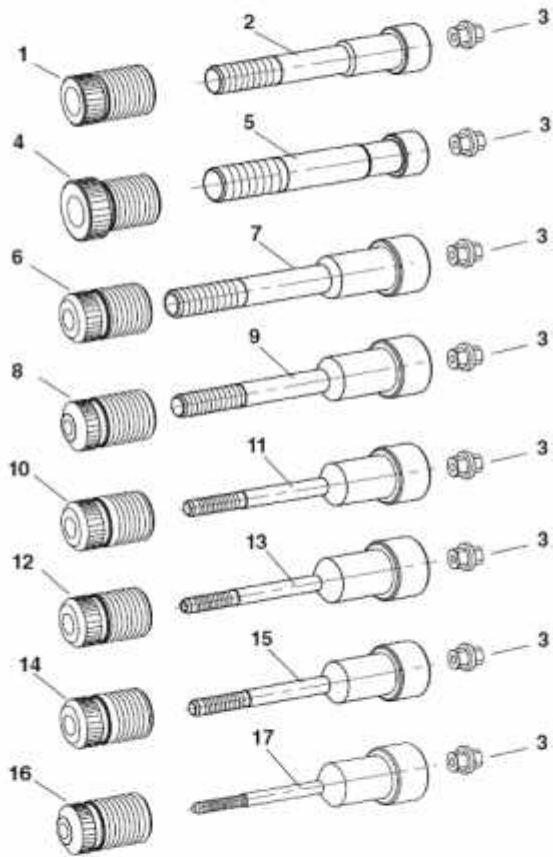
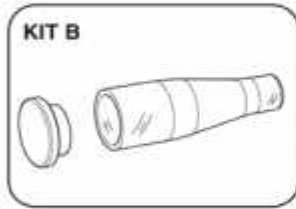

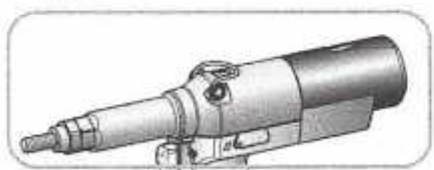
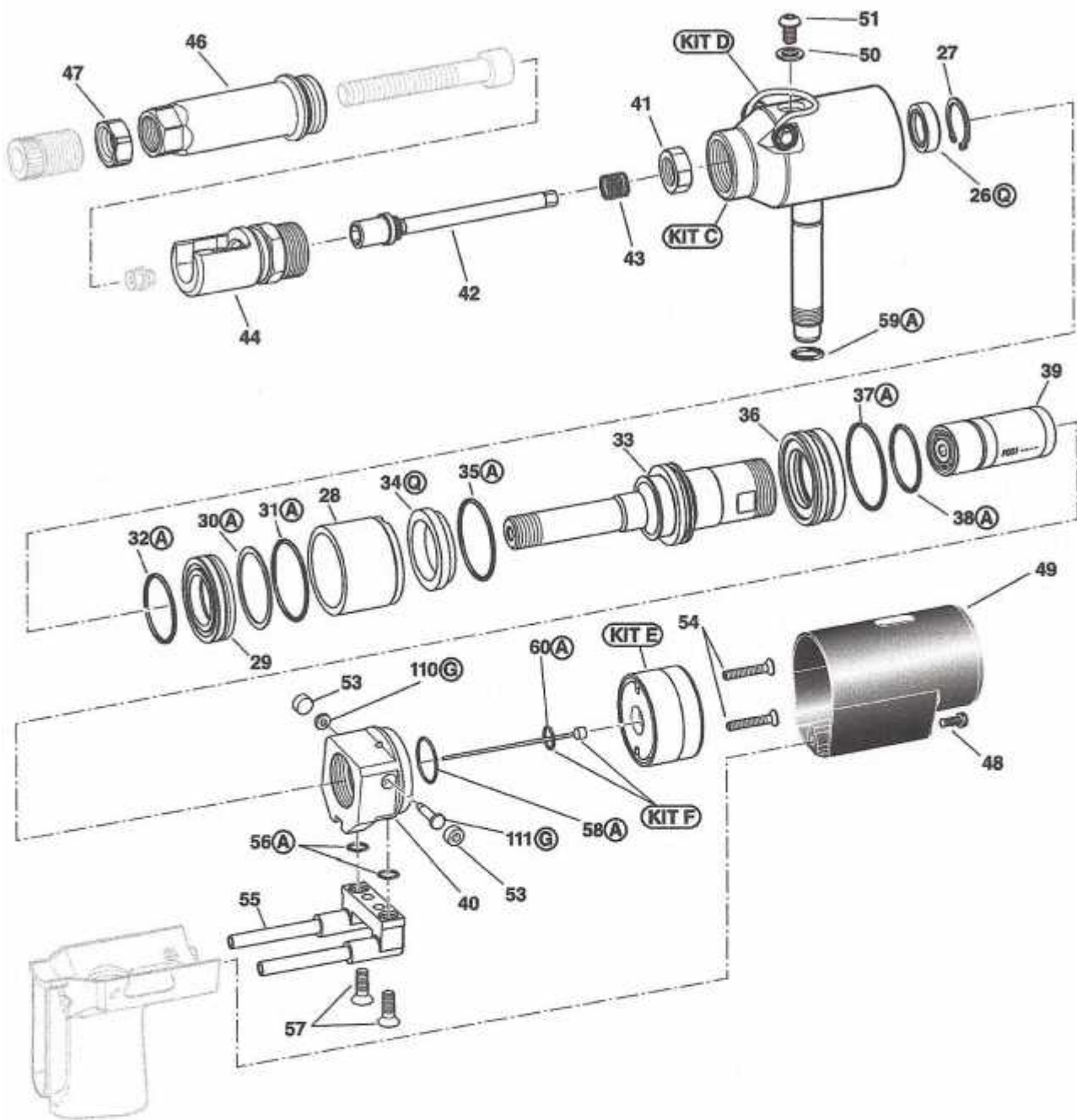

Tav. 02

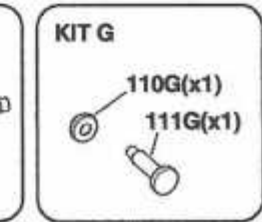
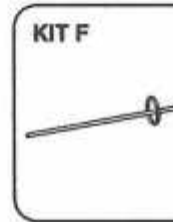
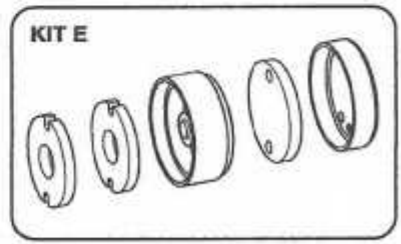
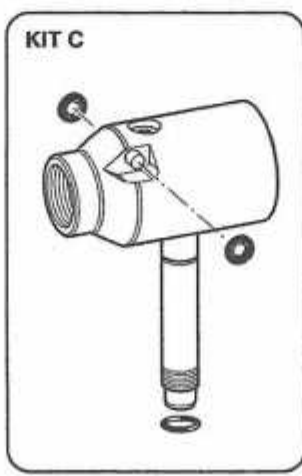

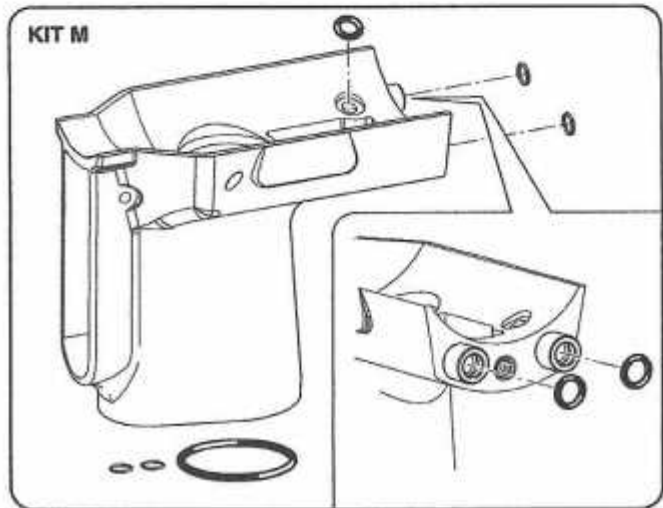
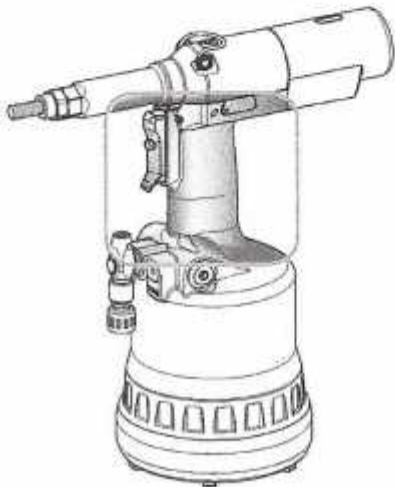
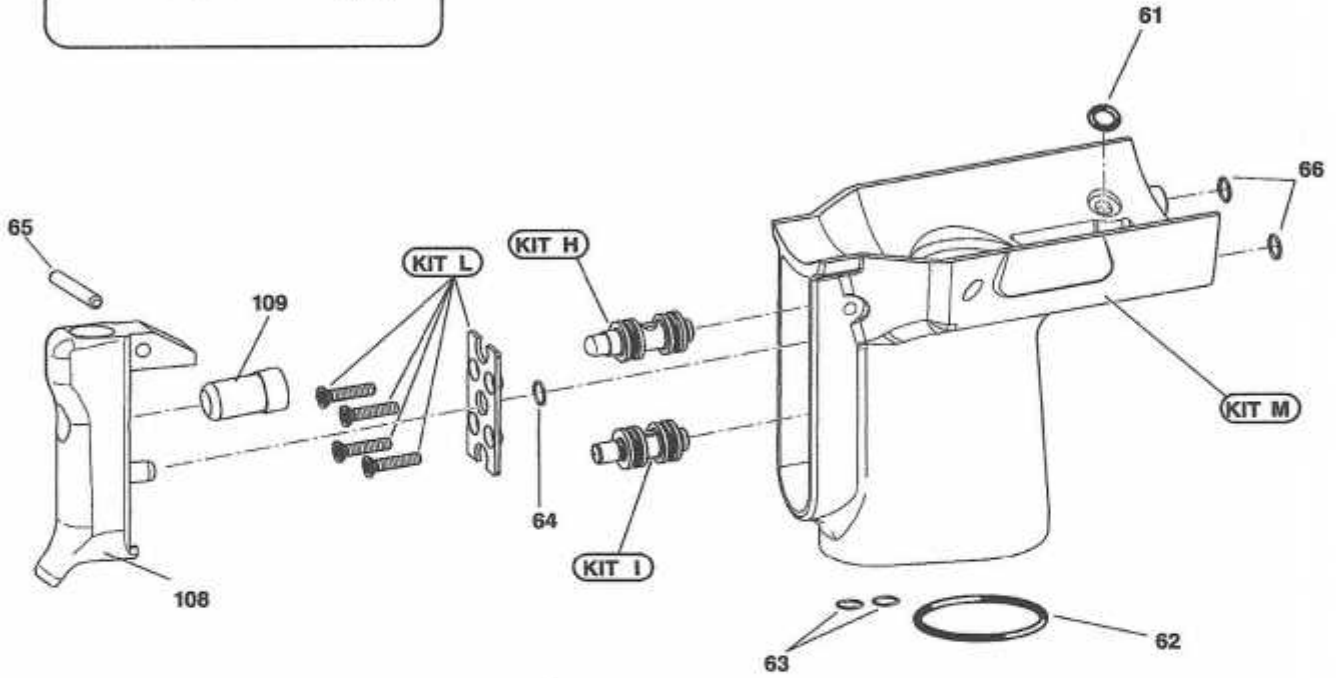
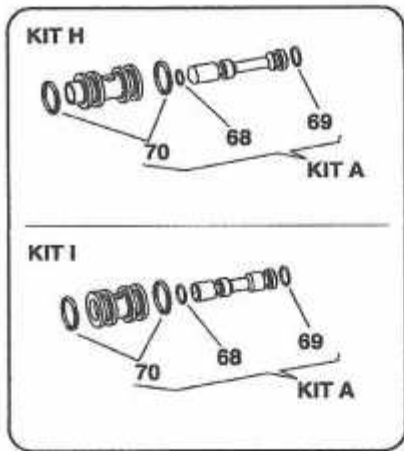

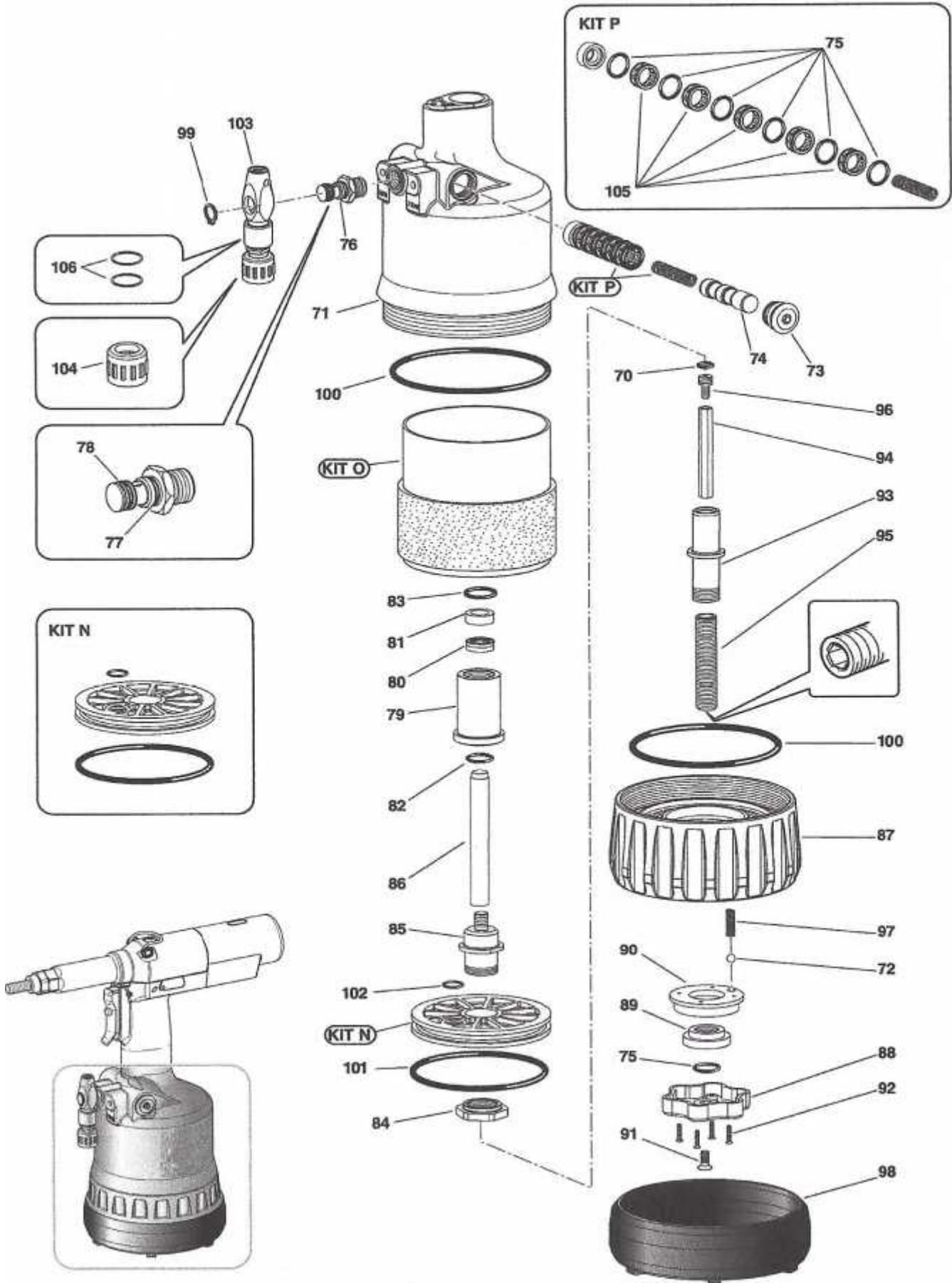

Air Motor Components

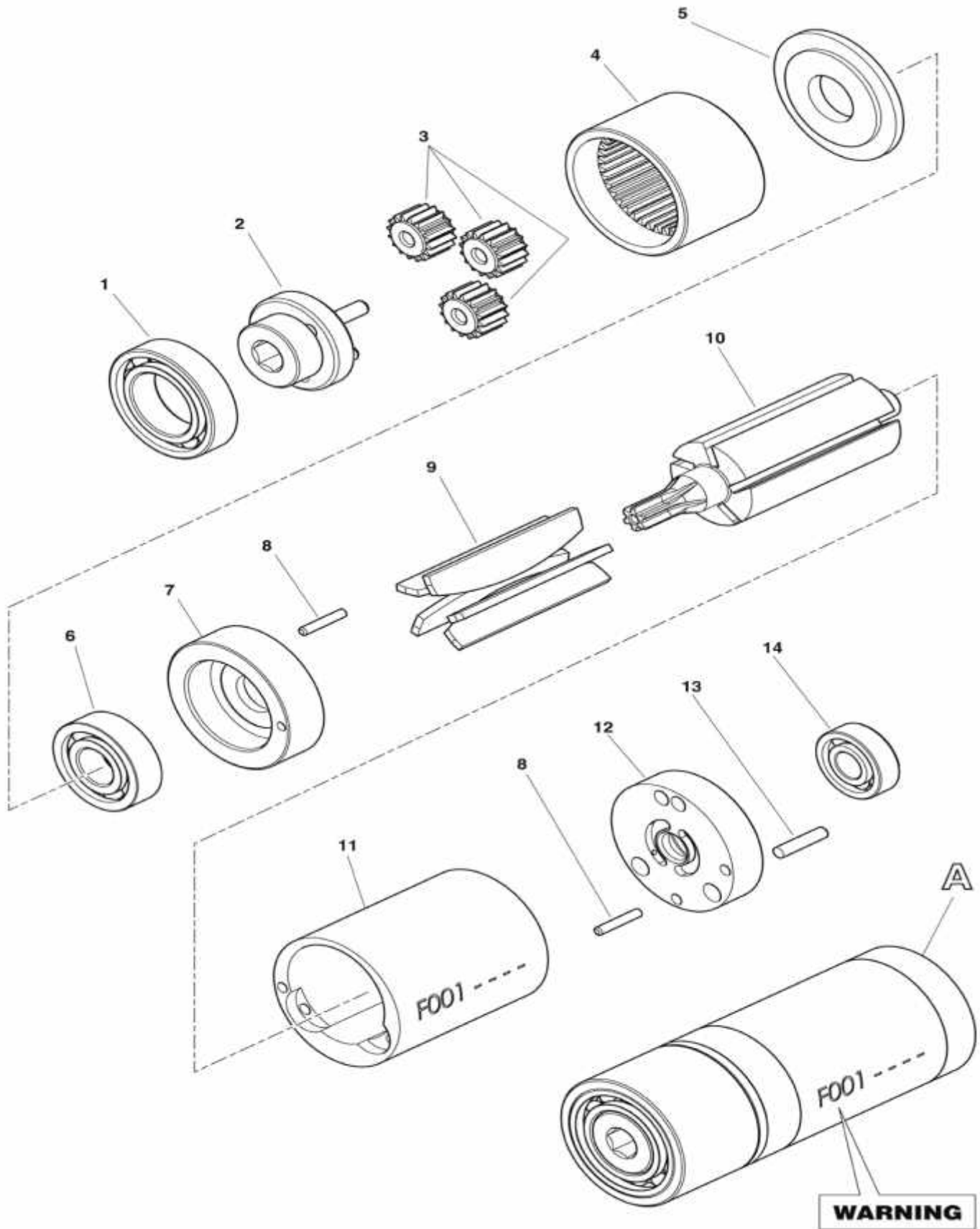

Parts List

Ref#	Qty	Part Number	DESCRIPTION	Ref#	Qty	Part Number	DESCRIPTION
Parts 1-17 for inch series. For metric components see page 13				58	1	Kit A	Gasket OR 5-612 PARKER (N674-70)
1	1	71345401	Head 3/8 UNC-UNF	59	1	Kit A / Kit C	Gasket OR 2-115 PARKER (N674-70)
2	1	71345409	Mandrel 3/8-16 UNC	60	1	Kit A	Gasket XR 008 PP180 B
3	1	713176	Hexagonal Reduction for Inch Mandrels	61	1	Kit A / Kit M	Gasket OR 008 DOWTY
4	1	71345402	Head 1/2 UNC	62	1	Kit A / Kit M	Gasket OR 2-120 PARKER (N674-70)
5	1	71345410	Mandrel 1/2-13 UNC	63	2	Kit A / Kit M	Gasket OR 2-006 PARKER (N674-70)
6	1	71345400	Head 5/16 UNC-UNF	64	1	Kit A	Gasket OR 2-106 PARKER (N674-70)
7	1	71345408	Mandrel 5/16-18 UNC	65	1	713401	Roller NRB ø3x19.8
8	1	71345399	Head 1/4 UNC-UNF	66	2	Kit A / Kit M	Gasket OR 2-009 PARKER (N674-70)
9	1	71345407	Mandrel 1/4-20 UNC	67	1	M72A00019	Push-button unit (both #108 &109)
10,12	1	71345398	Head 10 UNF-UNC	68	2	Kit A / Kit M	Gasket OR-2-003 PARKER (N674-70)
11	1	71345405	Mandrel 10-24 UNC	69	2	Kit A / Kit M	Gasket OR-2-005 PARKER (N674-70)
13	1	71345406	Mandrel 10-32 UNF	70	1	Kit A / Kit M	Gasket OR 2-010 PARKER (N674-70)
14	1	71345397	Head 8-32 UNC	71	1	72C00003	Body
15	1	71345404	Mandrel 8-32 UNC	72	1	713403	Ball ø 5.5
16	1	71345396	Head 6-32 UNC	73	1	71345272	Valve cap
17	1	71345403	Mandrel 6-32 UNC	74	1	71345273	Coil
22	1	709033	Plastic Case	75	7	Kit A / Kit P	Gasket OR-5-616 PARKER (N674-70)
24	1	72A00053	Oil container	76	1	72A00028	Air connector unit 1/4"
25	1	712225	Allen Wrench 4mm	77	2	Kit A	Gasket OR 1. 78x8.73 (N674-70)
26	1	Kit Q	Gasket BALSELE B 094063 (B-NEI)	78	2	Kit A	Gasket OR 1.7 8x 7.66 (N674-70)
27	1	713402	Seeger ring JV-25	79	1	713304	Guide stem connector
28	1	71345258	Jacket	80	1	Kit Q	Gasket TS 12 - 19 - 5,7 / L
29	1	71345261	Flange	81	1	Kit Q	Gasket BALSELE B 075047
30	1	Kit A	Ring PARBAK 8-028 N300-90 PARKER	82	1	Kit A	Gasket OR-5-615 PARKER (N674-70)
31	1	Kit A	Gasket OR 5-670 PARKER (N674-70)	83	1	Kit A	Gasket OR-2-116 PARKER (N552-90)
32	1	Kit A	Gasket OR 027 DOWTY (N674-70)	84	1	713319	Nut M22 X 1.25
33	1	71345264	Oil-dynamic piston	85	1	713320	Connector
34	1	Kit Q	Gasket BALSELE B 157118(B-NEI)	86	1	713315	Stem
35	1	Kit A	Gasket OR-2-126 PARKER (N674-70)	87	1	713197	Cover
36	1	71345260	Ring nut	88	1	713194	Knob
37	1	Kit A	Gasket OR-2-130 PARKER (N674-70)	89	1	713316	Ring nut
38	1	Kit A	Gasket OR-2-122 PARKER (N674-70)	90	1	713191	Disc
40	1	72A00188	Valve unit for motor control	91	1	712575	Screw TSEI M5X12 UNI 5933
41	1	71345263	Nut M 16 x 1	92	4	713404	Tapping screw TSP ø2.5x12 for plastic
42	1	72A00107	Driving unit	93	1	713317	Flanged connector
43	1	71345516	Spring for mandrel	94	1	713318	Driving shaft
44	1	71345515	Cone carrier for mandrel	95	1	713321	Double-thread screw
46	1	71345517	160 SP Tube (New Model Tool)	96	1	713322	Screw M5
47	1	71345411	Head ring nut - Inch Sizes	97	1	713199	Spring
47A	1	713170	Head ring nut - Metric Sizes	98	1	713196	Protection bottom
48	1	716198	Screw TCCE M4x12 UNI 5931	99	2	713434	Seeger ring ø 11 UNI 7435
49	1	72A00009	Fender motor	100	2	Kit A	Gasket OR 6-700 PARKER (N674-70)
50	1	710555	Washer ERM 400-004-4490	101	1	Kit A / Kit N	Gasket OR-2-340 PARKER (N674-70)
51	1	713405	Button head screw M6x10 UNI-ISO 7380	102	1	Kit A / Kit N	Gasket OR 2-109 PARKER (N674-70)
53	2	713308	Cap	103	1	72B00021	Overpressure valve unit 1/4" NPS
54	2	713406	Screw TSEI M4X25 UNI 5933	104	1	71C00305	Air connector unit
55	1	72A00007	Air connector	105	5	Kit A / Kit P	Casing
56	2	Kit A	Gasket OR 2-007 PARKER (N674-70)	106	1	713271	Gasket OR 2-014
57	2	716150	Screw TSEI M4x12 UNI 5933	108	1	71345648	Control push button
				109	1	71345649	Unscrewing button

Parts List

Kits			
A	1	74000026	Pneumatic Kit
B	1	74000027	Mandrel container kit
C	1	74000041	Oil-dynamic cylinder kit
D	1	74000025	Hook kit
E	1	74000021	Silencer kit
F	1	74000029	Rod kit
G	1	74000073	Obturator valve unit
H	1	74000033	Upper piston kit
I	1	74000034	Lower piston kit
L	1	74000035	Retaining plate kit
M	1	74000053	Handgrip kit
N	1	74000030	Pneumatic piston kit
O	1	74000031	Pneumatic jacket kit
P	1	74000023	Coil kit
Q	1	74000037	Oil-dynamic kit

Motor			
39	1	72A00125	Pneumatic Motor F001 (complete)
1	1	71C00764	Bearing 61801
2	1	71345645	Gear cage
3	3	71345644	Planetary gear
4	1	71345643	Crown gear
5	1	71345642	Washer
6	1	71C00763	Bearing AY7-ZZ
7	1	71345640	Connector
8	2	71C00761	Spring pin \varnothing 1.5 x 10 UNI 6875
9	5	71345639	Vanes
10	1	71345638	Rotor
11	1	71345637	Outside body
12	1	71345641	Back cap
13	1	713037	Pin 2 x 9.8
14	1	71C00762	Bearing 695-ZZ

Metric Components

1		713291	Head M10
2		71C00281	Mandrel M10x70 UNI 5931
3		72A00105	Hexagonal reduction M10
4		713292	Head M12
5		713177	Mandrel M12
6		72A00104	Hexagonal reduction M8-M12
7		713290	Head M8
8		71345529	Spacer for screw M8
107		71C00514	Mandrel M8x 70 UNI 5931
10		713289	Head M6
11		71345276	Spacer M6
12		71C00279	Mandrel M6x70 UNI 5931
13		72A00103	Hexagonal reduction M6
14		713288	Head M5
15		71345275	Spacer M5
16		71C00278	Mandrel M5x 70 UNI 5931
17		72A00102	Hexagonal reduction M5
18		713287	Head M4
19		71345274	Spacer M4
20		71C00277	Mandrel M4x65 UNI 5931
21		72A00101	Hexagonal reduction M4
9		71345831	Mandrel M8

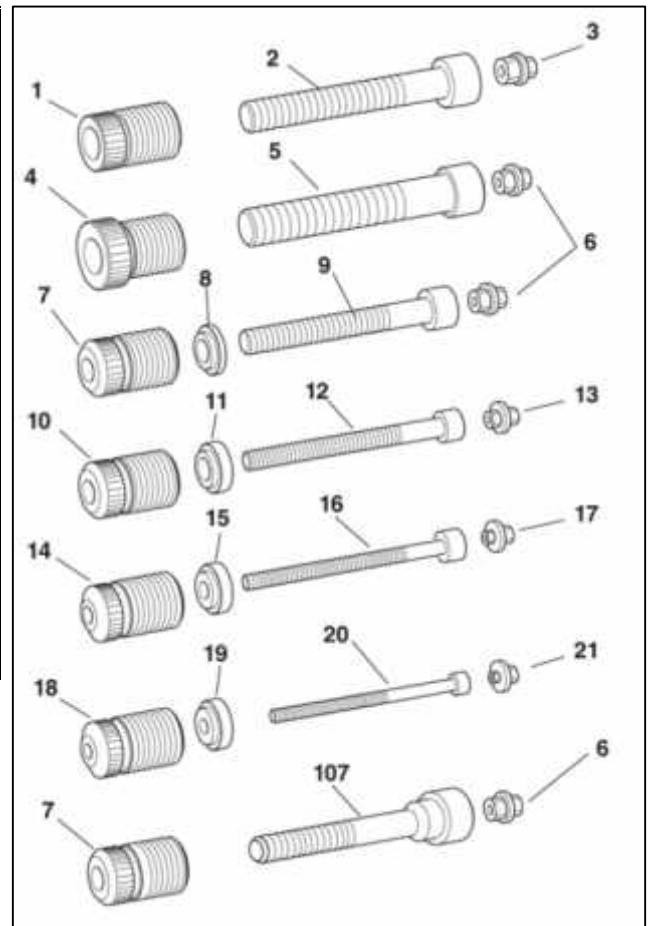

ARCONIC