



Service Manual

Original Instruction

Hydro-Pneumatic
Blind Rivet Tool

ProSet® XT4 Blind Rivet Tool - 76004

Hydro-Pneumatic Power Tool

Fig. 1

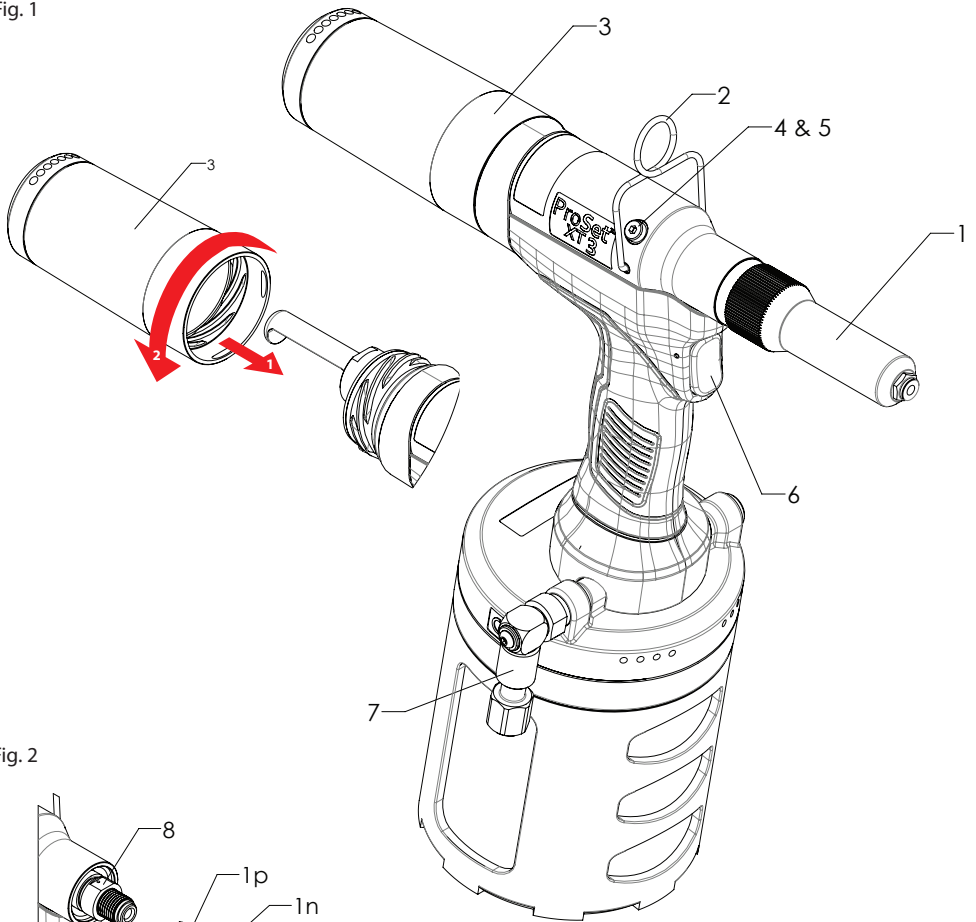

Fig. 2

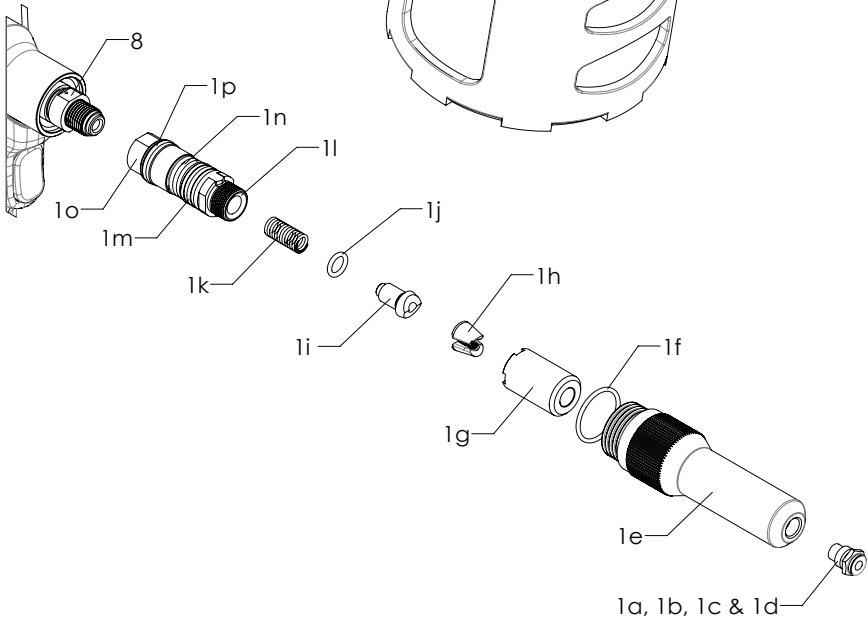

Fig. 3

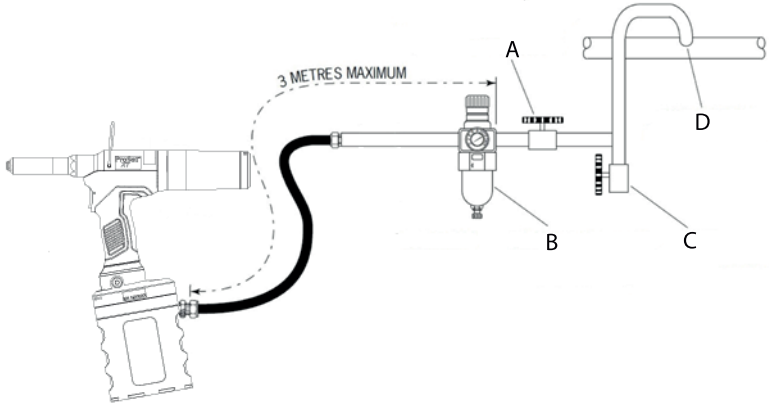

Fig. 4

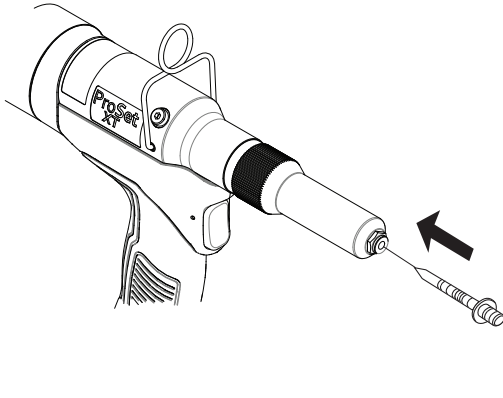

Fig. 5

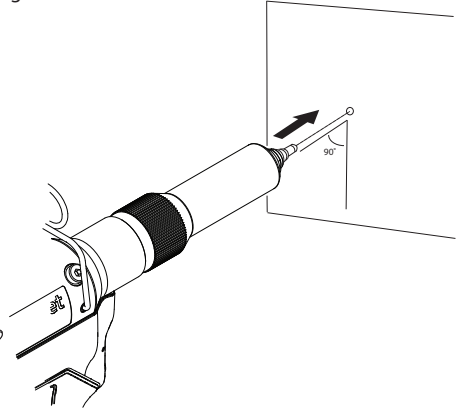

Fig. 6

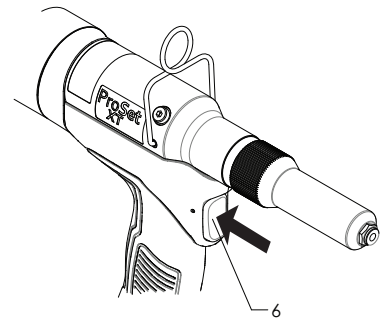

Fig. 7

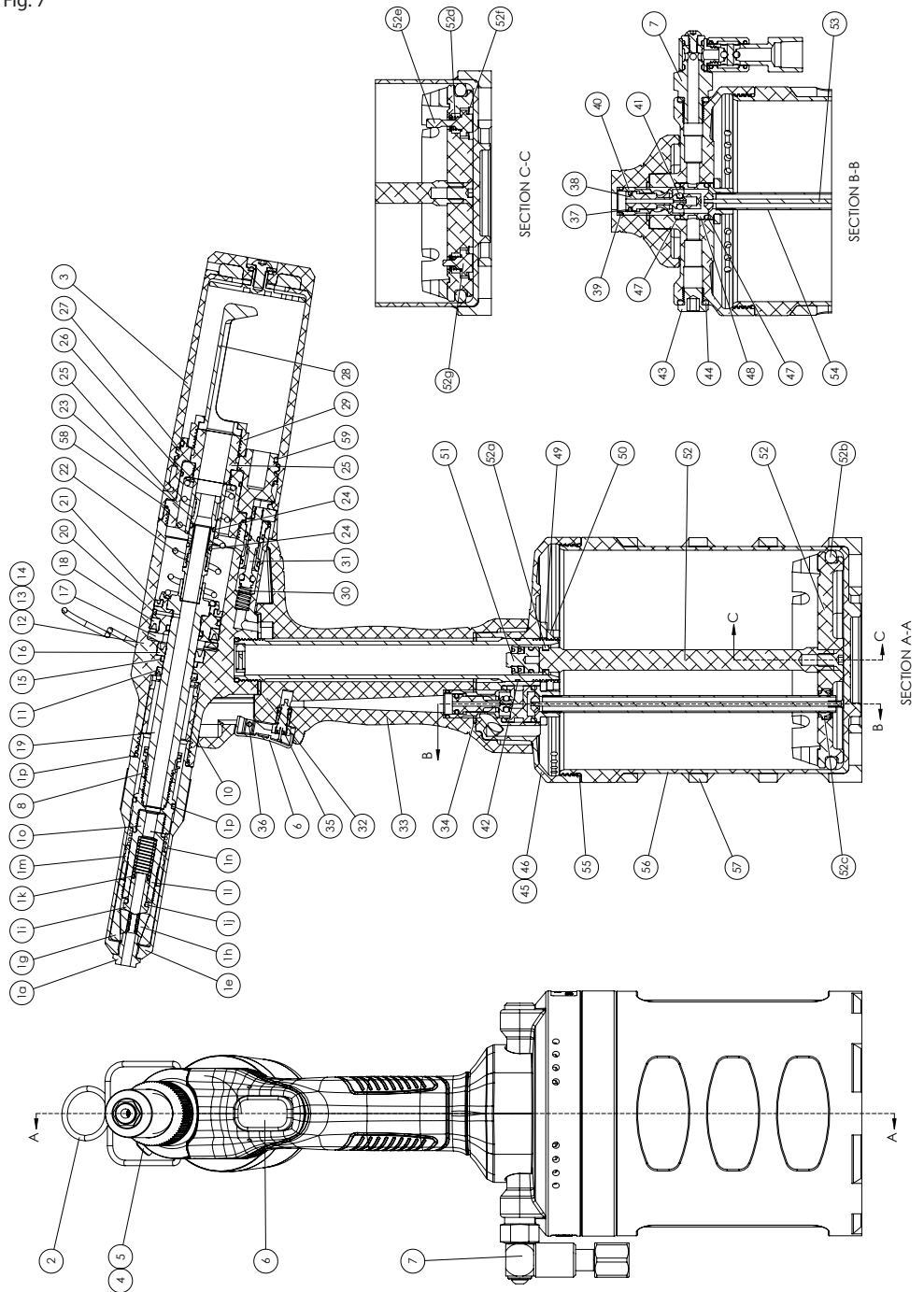
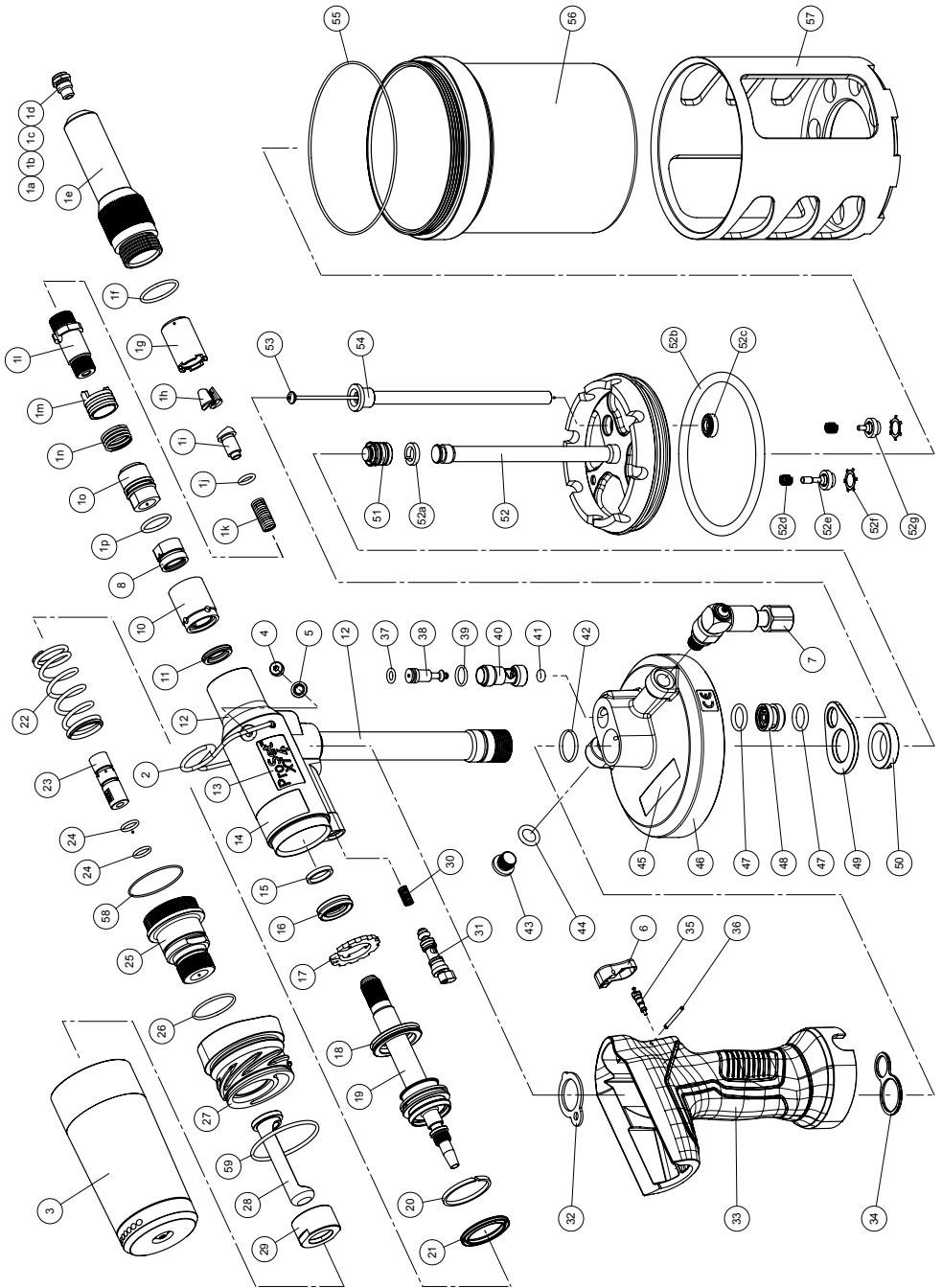

Fig. 8



Item	Part Number	Description	Standard Nose Equipment (Includes 4 Nose Pieces)	Qty	Spares	Item	Part Number	Description	Qty	Spares
1	76003-15000			1	Y	26	07003-00507	O Ring	1	Y
1a	PRN414	Nose Piece - 3.2 mm Rivets		1	Y	27	76003-05104	Collector Adapter Moulding	1	Y
1b	PRN514	Nose Piece - 4.0 mm Rivets		1	Y	28	76003-05101	Stem Deflector	1	Y
1c	PRN614	Nose Piece - 4.8 mm Rivets (filled)		1	Y	29	76003-05102	Deflector Retaining Nut	1	Y
1d	PRN811	Nose Piece - 6.4 mm Rivets		1	Y	30	76003-05304	Spring	1	Y
1e	76003-15001	Nose Casing		1	Y	31	76003-05300	MCS Valve Assembly	1	Y
1f	07003-00067	O Ring		1	Y	32	76003-02014	Gasket	1	Y
1g	DPN276-001	Jaw Guide		1	Y	33	76003-02016	Handle Assembly	1	Y
1h	PRG540-44	Jaws	1 Set	1	Y	34	76003-02025	Gasket	1	Y
1i	DPN276-006	Jaw Pusher		1	Y	35	07005-00088	Trigger Valve	1	Y
1j	DPN900-080	O Ring		1	Y	36	76003-02024	Trigger Pin	1	Y
1k	DPN901-019	Jaw Pusher Spring		1	Y	37	07003-00042	O Ring	1	Y
1l	76003-15002	Pulling Head		1	Y	38	71210-03402	Valve Spool	1	Y
1m	76003-15004	Jaw Guide Lock		1	Y	39	07003-00271	O Ring	1	Y
1n	DPN901-020	Spring		1	Y	40	71210-03401	Valve Body	1	Y
1o	76003-15003	Pulling Head Adapter		1	Y	41	07003-00288	O Ring	1	Y
1p	07003-00277	O Ring		1	Y	42	07003-00287	O Ring	1	Y
2	76003-02022	Suspension Hook		1	Y	43	07005-01274	1/8" BSP Plug	1	Y
3	76003-05200	Stem Collector		1	Y	44	07003-00127	O Ring	1	Y
4	07001-00405	M5 Socket Cap Head Screw		1	Y	45	74202-02090	POP-AVDEL Label	1	Y
5	07003-00194	M5 Bonded Seal		1	Y	46	76003-02001	Handle Base	1	Y
6	76003-02008	Trigger		1	Y	47	07003-00281	O Ring	2	Y
7	76003-03700	In-line On / Off Valve		1	Y	48	71210-02009	Valve Seat	1	Y
8	71210-02103	Locknut		1	Y	49	76003-02015	Top Plate	1	Y
9	07900-09404	Proset XT3 & XT4 Instruction Manual (not shown)		1	Y	50	71210-02014	Clamp Nut	1	Y
10	71210-02104	Seal Housing		1	Y	51	76004-03800	Intensifier Seal Assembly - XT4	1	Y
11	07003-00333	Lip Seal		1	Y	52	76004-03200	Pneumatic Piston Assembly - XT4	1	Y
12	76004-03300	Head Assembly - XT4		1	Y	52a	71230-03205	Guide Ring	1	Y
13	76004-02027	Proset XT4 Label		2	Y	52b	07003-00509	O Ring	1	Y
14	73200-02022	Safety Label		1	Y	52c	07003-00274	Rod Seal	1	Y
15	76003-02028	Bearing Ring		1	Y	52d	76003-03206	Spring	2	Y
16	07003-00273	Rod Seal		1	Y	52e	76003-03204	Exhaust Valve Body	1	Y
17	76003-02019	Seal Retainer		1	Y	52f	TP144-103	Retaining Ring	2	Y
18	07003-00504	Piston Seal		1	Y	52g	76003-03205	Exhaust Valve Body - Short	1	Y
19	76004-02120	Piston Assembly - XT4		1	Y	53	76003-03500	Valve Rod Assembly	1	Y
20	76003-02026	Bearing Tape		1	Y	54	76003-03600	Air Tube Assembly	1	Y
21	07003-00505	Lip Seal		1	Y	55	07003-00510	O Ring	1	Y
22	76003-02030	Spring		1	Y	56	76003-02002	Air Chamber	1	Y
23	76004-05105	Ejector Nozzle - XT4		1	Y	57	76003-02007	Air Chamber Sleeve	1	Y
24	07003-00511	O Ring		2	Y	58	07003-00508	O Ring	1	Y
25	76003-05110	End Cap Assembly		1	Y	59	07003-00530	O Ring	1	Y

©2017 Stanley Black & Decker inc.

All rights reserved.

The information provided may not be reproduced and/or made public in any way and through any means (electronically or mechanically) without prior explicit and written permission from STANLEY Engineered Fastening. The information provided is based on the data known at the moment of the introduction of this product. STANLEY Engineered Fastening pursues a policy of continuous product improvement and therefore the products may be subject to change. The information provided is applicable to the product as delivered by STANLEY Engineered Fastening. Therefore, STANLEY Engineered Fastening cannot be held liable for any damage resulting from deviations from the original specifications of the product.

The information available has been composed with the utmost care. However, STANLEY Engineered Fastening will not accept any liability with respect to any faults in the information nor for the consequences thereof. STANLEY Engineered Fastening will not accept any liability for damage resulting from activities carried out by third parties. The working names, trade names, registered trademarks, etc. used by STANLEY Engineered Fastening should not be considered as being free, pursuant to the legislation with respect to the protection of trade marks.

CONTENT

1. SAFETY DEFINITIONS	8
2. SPECIFICATION	9
2.1. TOOL SPECIFICATIONS.....	9
2.2. TOOL DIMENSION	10
2.3. PLACING SPECIFICATION	11
2.4. MAIN COMPONENTS LIST	12
2.5. STANDARD NOSE EQUIPMENT	12
3. TOOL SET UP	13
3.1. NOSE EQUIPMENT (Ref. fig. 2)	13
3.2. AIR SUPPLY (Ref. fig. 3)	13
3.3. PRINCIPLE OF OPERATION.....	14
4. OPERATION PROCEDURE	14
4.1. TOOL OPERATION (Ref. fig. 1, 4, 5, 6)	14
4.2. EMPTYING THE MANDREL COLLECTOR. (Ref. fig. 1)	14
5. SERVICING THE TOOL	15
5.1. MAINTENANCE FREQUENCY	15
5.2. NOSE EQUIPMENT	15
5.3. DAILY SERVICING	15
5.4. WEEKLY SERVICING	15
5.5. SERVICE KIT.....	16
5.6. PRIMING.....	16
6. MAINTENANCE	17
6.1. DISMANTLING THE TOOL.....	18
7. TROUBLESHOOTING GUIDE	21
8. GENERAL SAFETY DATA	22
8.1. HYSPIN® VG32 OIL SAFETY DATA	22
8.2. MOLY LITHIUM GREASE EP 3753 SAFETY DATA.....	23
8.3. MOLYKOTE® 55M GREASE SAFETY DATA.....	24
8.4. MOLYKOTE® 111 GREASE SAFETY DATA.....	24



This instruction manual must be read by any person installing or operating this tool with particular attention to the following safety rules.

1. SAFETY DEFINITIONS

The definitions below describe the level of severity for each signal word. Please read the manual and pay attention to these symbols.



DANGER: Indicates an imminently hazardous situation which, if not avoided, will result in death or serious injury.



WARNING: Indicates a potentially hazardous situation which, if not avoided, could result in death or serious injury.



CAUTION: Indicates a potentially hazardous situation which, if not avoided, may result in minor or moderate injury.

CAUTION: Used without the safety alert symbol indicates a potentially hazardous situation which, if not avoided, may result in property damage.

Improper operation or maintenance of this product could result in serious injury and property damage. Read and understand all warnings and operating instructions before using this equipment. When using power tools, basic safety precautions must always be followed to reduce the risk of personal injury.

SAVE ALL WARNINGS AND INSTRUCTIONS FOR FUTURE REFERENCE

WARNING:

- DO NOT use outside the design intent of Placing STANLEY Engineered Fastening Blind Rivets.
- Use only parts, fasteners, and accessories recommended by the manufacturer.
- DO NOT modify the tool in any way. Any modification to the tool is undertaken by the customer and will be the customer's entire responsibility and void any applicable warranties.
- Prior to use, check for misalignment or binding of moving parts, breakage of parts, and any other condition that affects the tool's operation. If damaged, have the tool serviced before using. Remove any adjusting key or wrench before use.
- The tool must be maintained in a safe working condition at all times and examined at regular intervals for damage and function by trained personnel. Any dismantling procedure will be undertaken only by trained personnel. Do not dismantle this tool without prior reference to the maintenance instructions.
- The operating supply air must not exceed 7 bar (100 PSI).
- Operators and others in work area must wear approved safety glasses with side shields. Always wear safety glasses and ear protection during operation.
- Dress properly. Do not wear loose clothing or jewellery. Keep your hair, clothing and gloves away from moving parts. Loose clothes, jewellery or long hair can be caught in moving parts.
- DO NOT operate a tool that is directed towards any person(s).
- DO NOT operate tool with the nose casing removed.
- Adopt a firm footing or a stable position before operating the tool.
- Prior to use, inspect airlines for damage, all connections must be secure. Do not drop heavy objects on Hoses. A sharp impact may cause internal damage and lead to premature hose failure.
- DO NOT lift the placing tool by the hose. Always use the placing tool handle.
- Vent holes must not become blocked or covered.
- Disconnect the air hose from the tool before performing any maintenance, attempting to adjust, fit or remove a nose assembly.
- Keep tool handles dry, clean, and free from oil and grease.
- When carrying the tool from place to place keep hands away from the trigger to avoid inadvertent activation.
- Never leave operating tool unattended. Disconnect air hose when tool is not in use.
- Adequate clearance is required for the tool operator's hands before proceeding.
- DO NOT abuse the tool by dropping or using it as a hammer.
- Keep dirt and foreign matter out of the hydraulic system of the tool as this will cause the tool to malfunction.

- Care should be taken to ensure that spent mandrels do not create a hazard.
- The mandrel collector must be emptied when approximately half full.
- DO NOT use the tool without mandrel collector installed.
- DO NOT let air exhaust opening on the mandrel collector face in the direction of the operator or other persons.
- Contact with hydraulic fluid should be avoided. To minimise the possibility of rashes, care should be taken to wash thoroughly if contact occurs.
- Material Safety Data Sheets for all hydraulic oils and lubricants is available on request from your tool supplier.

STANLEY Engineered Fastening policy is one of continuous product development and improvement and we reserve the right to change the specification of any product without prior notice.

2. SPECIFICATIONS

The ProSet® XT4 are hydro-pneumatic tools designed to place Stanley Engineered Fastening blind rivets at high speed

The tools feature a vacuum system for rivet retention and trouble free collection of the spent mandrels regardless of tool orientation.

When coupled to the relevant nose equipment the ProSet®XT4 can be used to place blind rivets in the range of Ø4.0mm to Ø6.4mm. Refer to the table on page <?> for a list of all rivets that can be placed.

The safety warnings on pages 4 & 5 must be followed at all times.

2.1. TOOL SPECIFICATION

	XT4	
Pull-Force: @5.5 bar	23.0 kN	5193 lbf
Air Supply Pressure: Min. to Max.	5.0 - 7.0 bar	72.5 –101.5 lbf/in ²
Oil Pressure: Pull @ 5.5 bar	395 bar	5729 lbf/in ²
Stroke: Minimum Piston Stroke	18.0 mm	0.71in.
Weight: Incl. nose equipment	2.16 kg	4.76 lb
Weight: without nose equipment	2.0 kg	4.41 lb
Free Air Volume: @ 5.5 bar	6.3 ltr	384.4 in ³
Cycle Time: Approximate	1.0 seconds	1.0 seconds
Noise Level: Uncertainty noise: k = 3db(A)	<77.9 dB(A)	<77.9 dB(A)
Vibration Level: Uncertainty vibration: k = 0.1 m/s ²	<2.5 m/s ²	<8.2 ft/s ²

2. 2. TOOL DIMENSIONS

Fig. 9

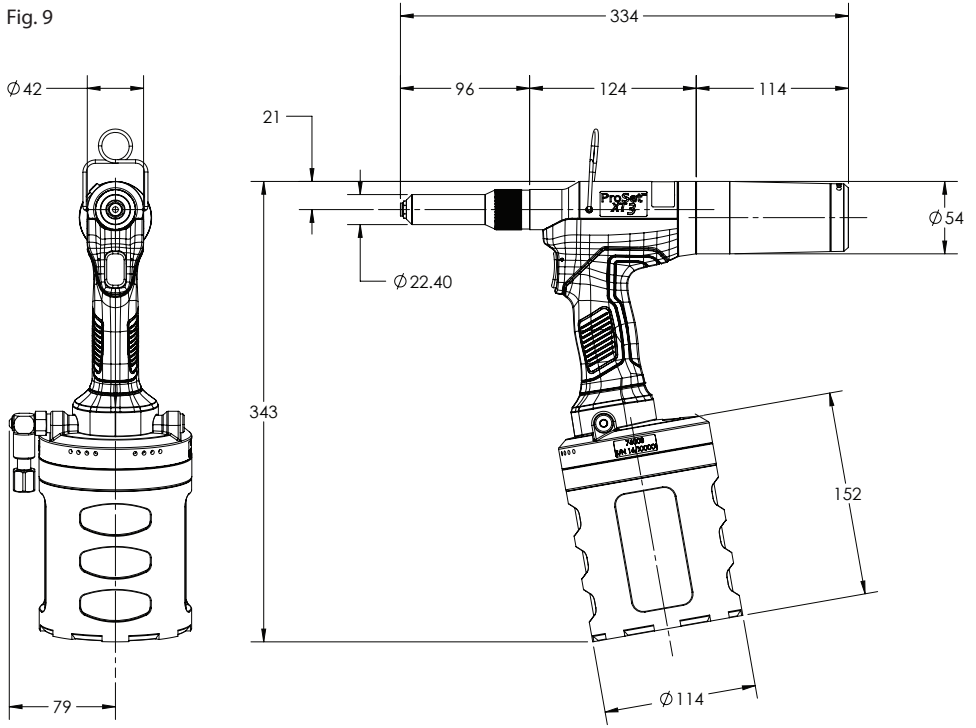

Dimensions in millimeters

2.3. PLACING SPECIFICATION

Rivet Type	Rivet Diameter mm [inches]										
	4,0 [5/32]	4,3	4,8 [3/16]	6,0	6,4 [1/4]	7,0	8,0	9,0	10,0	11,0	12,0
Open End	•*		•**		•						
Closed End	•*		•**		•						
HR	•*		•		•						
HS					•						
Multi-Grip	•*		•**		•						
TL	•*		•								
T-Rivet (Emhart)	•*		•		•						
Self-Pluggger	•*		•		•						
Ultra-Grip & UG (NPR)											
CD					•						
Avex®	•(2)		•(2)		•(2)						
Stavex®	•(2)		•(2)		•(1)(3)						
LSR/Bulbex®	•(2)		•(2)								
Avinox®/Avibulb®	•(2)		•(2)	•(2)							
Avinox®XT/Avibulb®XT					•(1)(3)						
T-Lok®		•(2)	•(2)								
Avdel® SR	•(2)		•(2)		•(2)						
Hemlok®					•(1)(3)						
Interlok											
Maxlok®			•(3)		•(3)						
Monobolt											
Avtainer®									•(1)(3)		
Avseal® (STD)				•(1)(3)		•(1)(3)	•(1)(3)	•(1)(3)	•(1)(3)		
Avseal® (Low Press)							•(1)(3)	•(1)(3)	•(1)(3)	•(1)(3)	•(1)(3)
Q Rivet	•(2)		•(2)		•(2)						
T Rivet (Avdel)			•(1)(2)		•(1)(2)						
Avdelmate®			•(2)		•(2)						
Klamp-Tite®BAPK											
Klamp-Tite® BAPKTR											
Avdelok®			•(3)		•(3)						

* Use PRG540-46 jaws and FAN276-064 jaw pusher assembly

** Use PRG540-46 jaws.

(1) Non-standard nose piece required

(2) Alternative type nose equipment available

(3) Non-standard nose equipment required.

For a full list of compatible nose equipment for each rivet type, together with assembly and maintenance instructions, please refer to the ProSet® nose equipment manual 07900-09414

2.4 MAIN COMPONENTS LIST

Refer to figure 1 & 2 and the table below.

Item	Part Number	Description	Qty
1	76003-15000	Standard nose equipment	1
2	76003-02022	Suspension hook	1
3	76003-05200	Mandrel collector	1
4	07001-00405	Oil plug	1
5	07003-00194	Seal	1
6	76003-02008	Trigger	1
7	76003-03700	On/Off valve	1
8	71210-02103	Locknut	1

2.5 STANDARD NOSE EQUIPMENT

Refer to figure 2 and the table below.

Item	Part Number	Description	Qty
1a	PRN414	Nose Piece - 3.2mm [1/8"]	1
1b	PRN514	Nose Piece - 4.0 mm [5/32"]	1
1c	PRN614	Nose Piece - 4.8 mm [3/16"] (Fitted)	1
1d	PRN811	Nose Piece - 6.4 mm [1/4"]	1
1e	76003-15001	Nose casing	1
1f	07003-00067	O ring	1
1g	DPN276-001	Jaw guide	1
1h	PRG540-44	Jaws	1 Set
1i	DPN276-006	Jaw pusher	1
1j	DPN900-060	O ring	1
1k	DPN901-019	Jaw pusher spring	1
1l	76003-15002	Pulling head	1
1m	76003-15004	Jaw guide lock	1
1n	DPN901-020	Spring	1
1o	76003-15003	Pulling head adapter	1
1p	07003-00277	O ring	1

For additional nose equipment please refer to the ProSet® Nose Equipment Manual 07900-09414 or visit www.stanleyengineeredfastening.com/resource-center/document-library

For a full list of tool accessories, please refer to the ProSet Accessories Manual 07900-09415.

3. TOOL SET UP

IMPORTANT - READ THE SAFETY WARNINGS ON PAGE 8 & 9 CAREFULLY BEFORE PUTTING INTO SERVICE.

IMPORTANT - THE AIR SUPPLY MUST BE TURNED OFF OR DISCONNECTED BEFORE FITTING OR REMOVING THE NOSE ASSEMBLY.

3.1 NOSE EQUIPMENT (Ref. fig. 2)

Item numbers in bold refer to the components in figures 1 & 2 and the tables on page <?>.

The complete tool will be supplied pre-assembled with the Nose Piece for 4.8mm [3/16"] rivets.

Three additional Nose Pieces for 3.2mm [1/8"], 4.0mm [5/32"] and 6.4mm [1/4"] rivets are supplied separately.

Mounting the nose piece

- The air supply must be disconnected.
- Select the correct nose piece for the rivet to be installed.
- Remove the nose casing (**1e**), including nose piece (**1a,b,c or d**), and O ring (**1f**)
- Remove the nose piece (**1a,b,c or d**) from the nose casing (**1e**)
- Select the relevant size nose piece and assemble in reverse order.

Removing complete nose equipment.

- The air supply must be disconnected.
- Remove the nose casing (**1e**), including the nose piece (**1a,b,c or d**), and O ring (**1f**) from the tool.
- Pull back the jaw guide lock (**1m**) against the spring (**1n**) and then remove the jaw guide (**1g**).
- Remove the jaws (**1h**) from the jaw guide (**1g**).
- Remove jaw pusher (**1i**), O ring (**1j**), and Jaw pusher spring (**1k**), from the pulling head (**1l**).
- Remove the pulling head assembly (**1q**) from the tool piston using spanners

Mounting the complete nose equipment

- The air supply must be disconnected
- Any worn or damaged part should be replaced.
- Clean and check wear on jaws (**1h**).
- Ensure that the jaw pusher (**1i**) or the jaw pusher spring (**k**) are not distorted.
- Lightly coat jaws (**1h**) with moly lithium grease.
- Drop Jaws (**1h**) into the jaw guide (**1g**).
- Insert jaw pusher (**1i**) and O ring (**1j**) into the pulling head (**1l**).
- Pull back the jaw guide lock (**1m**) and screw the jaw guide (**1g**) fully on to the pulling head (**1l**).
- Release the jaw guide lock (**1m**) and then partially unscrew the jaw guide (**1g**) until the jaw guide lock (**1m**) tooth clicks into the next slot on the jaw guide (**1g**).
- Place nose casing (**1e**) over the jaw guide (**1g**) and tighten fully onto the tool.

Nose assemblies should be serviced at weekly intervals. You should hold some stock of all internal components of the nose assembly and nose tips as they will need regular replacement.

3.2 AIR SUPPLY (Ref. fig. 3.)

Components

- Stop cock (used during maintenance of filter/regular or lubricated units)
 - Pressure regulator and filter (daily drain)
 - Main supply drain point
 - Take off point from main supply
- All tools are operated with compressed air at a minimum pressure of 5.0 bar.
 - Pressure regulators and automatic oiling/filtering systems to be used on the main air supply within 3 metres of the tool (see fig. 3).

- Air supply hoses will have a minimum working effective pressure rating of 150% of the maximum pressure produced in the system or 10 bar, whichever is the highest.
- Air hoses must be oil resistant, have an abrasion resistant exterior and be armoured where operating conditions may result in hoses being damaged.
- All air hoses **MUST** have a minimum bore diameter of 6.4 millimetres.
- Check for air leaks. If damaged, hoses and couplings must be replaced by new items.
- If there is no filter on the pressure regulator, bleed the airline to clear it of accumulated dirt or water before connecting air hose to the tool.

3.3 PRINCIPLE OF OPERATION

CAUTION - CORRECT SUPPLY PRESSURE IS IMPORTANT FOR PROPER FUNCTION OF THE INSTALLATION TOOL. PERSONAL INJURY OR DAMAGE TO EQUIPMENT MAY OCCUR WITHOUT CORRECT PRESSURES. THE SUPPLY PRESSURE MUST NOT EXCEED THAT LISTED IN THE PLACING TOOL SPECIFICATION

Item numbers in bold refer to the components in figures 1 & 2 and the tables on page 11.

When the pneumatic hose is connected to the placing tool, the pull and return cycles of the tool are controlled by depressing and releasing the trigger (**6**) located in the handle.

- Air supply is disconnected.
- Connect the appropriate nose equipment as described on page 10 & 11.
- Connect the pneumatic hose to the air on/off valve (**7**).
- Connect the pneumatic hose mains air supply.
- Switch on the mains supply to the tool by sliding the air on/off valve (**7**) to the up position.
- Air is now be supplied to the tool and the vacuum system is in operation.
- Pull and release the trigger (**6**) a few times to the full stroke of the tool to check operation. Observe action of tool. Check for fluid and/or air leaks.

4. OPERATION PROCEDURE

4.1 TOOL OPERATION (Ref. fig. 1, 4, 5, 6)

Installing a blind rivet

- Ensure that the mandrel collector (**3**) is fitted.
- Insert rivet mandrel into the nose piece (**1a,b,d or d**). The vacuum system will retain the rivet in the nose piece.
- Position the tool.
- Ensure nose equipment is at right angle (90°) to the work piece.
- Pull and hold trigger (**6**) until the rivet is fully set in the application.
- When the rivet has been set completely, release the trigger (**6**). The tool will return to its initial position automatically. The mandrel is automatically dropped into the mandrel collector (**3**) by the vacuum system.
- Mandrel collector must be emptied before it is half full.

CAUTION –DO NOT FORCE THE INSERTION OF A RIVET MANDREL OR RIVET BODY. THIS WILL CAUSE DAMAGE TO THE TOOL AND/OR APPLICATION.

4.2 EMPTYING THE MANDREL COLLECTOR. (Ref. fig. 1)

CAUTION - DO NOT USE THE TOOL WHEN THE MANDREL COLLECTOR IS REMOVED

- The tool is fitted with a quick connect/release mandrel collector (**3**).
- A 60° rotation removes or replaces the mandrel collector.
- Removing the mandrel collector (**3**) from the tool automatically turns OFF the vacuum rivet retention and mandrel extraction system.
- Refitting the mandrel collector turns the vacuum system ON.

5. SERVICING THE TOOL

5.1 MAINTENANCE FREQUENCY

Regular servicing must be carried out by trained personnel and a comprehensive inspection performed annually or every 500,000 cycles, whichever is sooner.



DISCONNECT AIR SUPPLY



CAUTION - *Never use solvents or other harsh chemicals for cleaning the non-metallic parts of the tool. These chemicals may weaken the materials used in these parts.*

5.2 NOSE EQUIPMENT

Nose assemblies need to be serviced at weekly intervals or every 5,000 cycles. Hold some stock of all internal components of the nose assembly and nose pieces, they need regular replacement.

- Disconnect the air supply
- Remove the complete nose assembly using the procedure described in section 3.1.
- Inspect all components. Any worn or damaged parts must be replaced by a new part.
- Particularly check wear on the Jaws (**1h**).
- Clean all parts and apply moly lithium Grease (07992-00020) to jaws (**1h**) and taper bore of jaw guide (**1g**).
- Assemble according to fitting instructions in section 3.1.

5.3 DAILY SERVICING

- Before use, check the tool, hose and couplings for air leaks and oil leaks. If damaged, remove the tool from service and replace affected items with new parts.
- If there is no filter on the pressure regulator, bleed the airline to clear it of accumulated dirt or water before connecting the air hose to the tool. If there is a filter, drain it.
- Check that the nose equipment (**1**) is correct for the rivet to be placed and that it is fitted properly.
- Check that the stroke of the tool meets the minimum specification (ref. 2.1).
- The mandrel collector (**3**) must fitted to the tool.
- Check that the air chamber is fully tightened onto the tool body.

5.4 WEEKLY SERVICING

- Check the tool, hose and couplings for air leaks and oil leaks. If damaged, remove the tool from service and replace affected items with new parts.

5.5 SERVICE KIT

For an easy complete service, Stanley Engineered Fastening offers the complete Service Kit below.

Service Kit 76003-99990					
Item	Part Number	Description	Item	Part Number	Description
1	07900-00008	7/16 x 1/2 A/F Spanner	12	07900-00685	Insertion Rod
2	07900-00012	9/16 x 5/8 A/F Spanner	13	07900-00692	Trigger Valve Extractor
3	07900-00015	5/8 x 11/16 A/F Spanner	14	07900-00698	Stop Nut
4	07900-00158	2mm Pin Punch	15	07900-00700	Priming Pump Assembly
5	07900-00164	Circlip Pliers	16	07900-00706	Location Spigot Assembly
6	07900-00224	4mm Hexagonal Wrench	17	07900-00755	Grease - Molykote 111
7	07900-00351	3mm Hexagonal Wrench	18	07900-01085	Guide Tube
8	07900-00469	2.5mm Hexagonal Wrench	19	07900-01086	Piston Sleeve
9	07900-00670	Piston Bullet	20	07992-00020	Grease - Moly Lithium
10	07900-00672	Spanner Assembly	21	07992-00075	Grease - Molykote 55M
11	07900-00677	Seal Extractor			

5.6 PRIMING

Priming is necessary after the tool has been dismantled and prior to operating. It may also be necessary to restore the full stroke after considerable use, if the stroke has been reduced and fasteners are not now being fully placed by one operation of the trigger.

Oil Details

The recommended oil for priming is Hyspin® VG32 available in 0.5l (part number 07992-00002) or one gallon containers (part number 07992-00006).

Priming Kit

To enable you to follow the priming procedure below you will need to obtain a priming kit.

Priming Kit 07900-00688		
Item	Part Number	Description
1	07900-00351	3mm Hexagonal Wrench
2	07900-00700	Priming Pump
3	07900-00224	4mm Hexagonal Wrench

Priming Procedure

IMPORTANT - DISCONNECT THE TOOL FROM THE AIR SUPPLY OR SWITCH OFF AT ON/OFF VALVE ASSEMBLY 7. REMOVE NOSE ASSEMBLY OR SWIVEL HEAD COMPONENTS.

All operations must be carried out on a clean bench, with clean hands in a clean area.

Ensure that the oil is perfectly clean and free from air bubbles.

Care MUST be taken at all times, to ensure that no foreign matter enters the tool, or serious damage may result.

Before priming, empty the oil from tool as follows.

- Switch OFF air supply at ON/OFF Valve (7.)
- Remove all nose equipment (1.) Refer to section 3.1.
- Remove Bleed Screw (4) and Seal (5.)
- Invert tool over suitable container, switch ON air supply at ON/OFF Valve (7) and actuate tool.
- Residual oil in the tools hydraulic system will empty through bleed screw orifice.

CARE SHALL BE TAKEN TO ENSURE THAT THE BLEED HOLE IS NOT DIRECTED TOWARDS THE OPERATOR OR OTHER PERSONNEL.

- Switch air supply OFF at ON/OFF Valve (7.)
- Screw priming pump (07900-00700) into bleed screw port, utilizing Seal (5.)
- Actuate Priming Pump by pressing down and releasing several times until resistance is evident and the Head Piston starts to move rearward.

ENSURE PUMP IS KEPT 'SQUARE' TO BLEED SCREW PORT DURING PRIMING OPERATION TO PREVENT BREAKAGE OF BLEED NIPPLE ON PRIMING PUMP.

- Remove the priming pump, surplus oil will expel from bleed screw port.
- Replace the Bleed Screw (4) together with Seal (5.)
- Switch ON air supply at ON/OFF Valve (7.)
- Check that the stroke of the head piston reaches specification. If not repeat above procedure.
- Switch OFF air supply and refit nose equipment. Refer to section 3.1.
- Check that the stroke of the tool meets the minimum specification of 26 mm.
- To check the stroke, measure the distance between the front face of the Jaw Guide (1g) and the front of the Head (12), BEFORE pressing the trigger and when the trigger is fully actuated. The stroke is the difference between the two measurements. If it does not meet the minimum specification, repeat the Priming Procedure.

6. Maintenance

IMPORTANT

SAFETY WARNINGS APPEAR ON PAGE 7 & 8.

THE EMPLOYER IS RESPONSIBLE FOR ENSURING THAT TOOL MAINTENANCE INSTRUCTIONS ARE GIVEN TO THE APPROPRIATE PERSONNEL. THE OPERATOR SHOULD NOT BE INVOLVED IN MAINTENANCE OR REPAIR OF THE TOOL UNLESS PROPERLY TRAINED.

Every 500,000 cycles the tool must be completely dismantled and inspected Components must be replaced where worn or damaged. All O rings and seals should be replaced with new ones and lubricated with Molykote 55M grease (07992-00075) for pneumatic sealing or Molykote 111 (07900-00755) for hydraulic sealing.

▲ WARNING

The airhose must be disconnected before any servicing or dismantling is attempted unless specifically instructed otherwise.

The dismantling operation must be carried out in clean conditions.

Before proceeding with dismantling, empty the oil from the tool as follows.

Before priming, empty the oil from tool as follows.

(Ref. fig. 1)

- Switch OFF air supply at ON/OFF Valve (7.)
- Remove all nose equipment (1.) Refer to section 3.1.
- Remove Bleed Screw (4) and Seal (5.)
- Invert tool over suitable container, switch ON air supply at ON/OFF Valve Assembly (7) and actuate tool.
- Residual oil in the tools hydraulic system will empty through bleed screw orifice.

For complete tool servicing we advise that you proceed with dismantling of sub-assemblies in the order shown below.

Refer to fig. 7 & 8.

6.1 DISMANTLING THE TOOL**6.1.1 Nose Equipment**

- Unscrew the Nose Casing (1e), including the Nose Piece (1a), and O Ring (1f).
- Pull back the Jaw Guide Lock (1m) against the Spring (1n) and then unscrew the Jaw Guide (1g).
- Remove the Jaws (1h) from the Jaw Guide (1g).
- At this point the Jaws (1h) can be cleaned and a light coating of Moly Lithium grease applied or replaced if worn.
- Remove Jaw Pusher (1i), O Ring (1j), and Spring (1k), from the Pulling Head (1l).
- Using spanners, loosen Locknut (8) and unscrew the Pulling Head Adapter (1o), Pulling Head (1l), Jaw Guide Lock (1m) and Spring (1n) from the tool piston.
- Removal of the Pulling Head (1l), Jaw Guide Lock (1m) and Spring (1n) from the Pulling Head Adapter (1o) should not be necessary.

Reassemble as follows:

- Any worn or damaged part should be replaced.
- Clean and check wear on Jaws.
- Ensure that the Jaw Pusher (1i) or the Spring (1k) are not distorted.
- Assemble in reverse order to the removal instructions above.
- Lightly coat Jaws (1h) with Moly Lithium grease.
- Drop Jaws (1h) into the Jaw Guide (1g).
- Insert Jaw Pusher (1i) and O Ring (1j) into the Pulling Head (1l).
- Pull back the Jaw Guide Lock (1m) and screw the Jaw Guide (1g) fully on to the Pulling Head (1l). Release the Jaw Guide Lock (1m) and then partially unscrew the Jaw Guide (1g) until the Jaw Guide Lock (1m) tooth clicks into the next slot on the Jaw Guide (1g).
- Place Nose Casing (1e) over the Jaw Guide (1g) and screw fully onto the tool.

6.1.2 Head Assembly

- Rotated the Stem Collector (3) anti-clockwise and remove from the Collector Adapter (27). Refer to fig. 3.
- Unscrew the Deflector Retaining Nut (29) together with the Deflector (28).
- Pull off the Collector Adapter (27) and O ring (59).
- Unscrew the End Cap Assembly (25) together with O ring (26) and O ring (58). Care should be taken as the End Cap Assembly will be under load from the Spring (22).
- Remove Spring (22).
- Unscrew and remove Locknut 8 from the Piston Assembly (19).
- Push the Piston Assembly (19), together with the Ejector Nozzle (23) and O rings (24), to the rear and out of the Head Assembly (12) taking care not to damage the cylinder bore or piston shaft.
- Using circlip pliers (07900-00164) remove the seal retainer (17) then push the Rod Seal (16) and Bearing Tape (15) to the rear and out of the Head Assembly (12).
- Remove the Seal Housing (10) and Lip Seal (11).

- Remove the MCS Valve Assembly (31) and Spring (30) from the rear of the Head Assembly (12).
- Once removed check the condition of Rod Seal (12) and discard if damaged.
- Check the condition of Lip Seal (18), Lip Seal (21) and Bearing Tape (20) on the Piston assembly (19). Remove and discard if damaged.
- Check the condition of the O ring (24) on the Ejector Nozzle (23). Remove and discard if damaged.
- It should not be necessary to remove the Ejector Nozzle (23) from the Piston Assembly (19).

Assemble in reverse order noting the following points:

- Place Rod Seal (16) onto the insertion rod (07900-00685) ensuring correct orientation.
- Locate the guide tube (07900-01085) into the rear of the Head Assembly (12) then push insertion rod, with the Rod Seal in place, through the guide tube to install the seal in the Head Assembly.
- Pull the insertion rod out followed by the guide tube.
- The chamfered edge of the Seal Retainer (17) must face forward with the gap in the two o'clock position.
- Ensuring the correct orientation, lubricate and fit Lip Seal (18), Lip Seal (21) and Bearing Tape (20) onto the Piston Assembly (19).
- Screw the piston sleeve (07900-01086) into the rear of the Head Assembly (12) and lubricate the cylinder bore. Attach the piston bullet (07900-00670) onto the Piston Assembly (19) thread. Lubricate the piston bullet and the Piston Assembly shaft and the seals.
- Push the Piston Assembly (19) with the seals through the piston sleeve and into the rear of the Head Assembly (12). The Piston Assembly should be inserted into the Head Assembly as far as it will go. Remove the piston bullet from the Piston Assembly and remove the piston sleeve from the Head Assembly.
- Pulling Head Adapter (10) must be fully tightened onto the Piston Assembly (19) before tightening Locknut (8) against it.
- Reprime in accordance with the instructions on page #.

6.1.3 Air Chamber and Pneumatic Piston Assembly

- Clamp the Head Assembly (12) of the inverted tool in a vice with soft jaws.
- Remove the Air Chamber Sleeve (57).
- Using a wrench, unscrew the Air Chamber (56) including O Ring (55) and remove from the Handle Base (46) and Pneumatic Piston Assembly (52).
- Remove the Pneumatic Piston Assembly (52) together with Guide Ring (52a), O Ring (52b), Lip Seal (52c) and the Exhaust Valves (52d) to (52g).
- Engage the seal extractor (07900-00677) into the Intensifier Seal Assembly (51) and then withdraw this from the Hydraulic tube of the Head Assembly (12).

Assemble in reverse order noting the following points:

- Seals should be checked for damage and replaced as necessary. Lubricated pneumatic seals with Molykote 55M grease (07992-00075) and hydraulic seals with Molykote 111 grease (07900-00755).
- Ensure that the Air Chamber (56) is screwed fully into the Handle Base (46) so that there are no visible gaps between the parts.

6.1.4 Air Valve, Handle Base and Handle Assembly

- Remove the Air Chamber (56) and Pneumatic Piston Assembly (52) as described above.
- Using spanner (07900-00672) and location spigot assembly (07900-00706), unscrew Clamp Nut (50) and remove together with the Top Plate (49), Air Tube Assembly (54) and Valve Rod Assembly (53).
- Remove the Handle Base (46) from the Handle Assembly (33).
- Push the Valve Seat (48) from the Handle Base (46), together with O Rings (47).
- Pull the Valve Spool Assembly (37), (38), (40) and (41) from the Handle Assembly (33). Remove O Ring (39) from the Handle counterbore.

- Remove Gasket **(34)** from the Handle Assembly **(33)**.
- Remove O Ring **(42)** from the Hydraulic tube of the Head Assembly **(12)**.
- Separate the Handle Assembly **(33)** from the Head Assembly **(12)**.
- Remove Gasket **(32)** from the Head Assembly **(12)**.

Assemble in reverse order noting the following points:

- Seals and gaskets should be checked for damage and replaced as necessary. Lubricated seals and gaskets with Molykote 55M grease (07992-00075).
- Apply Loctite 243 to Clamp Nut **(50)** and tighten to torque 14.91 Nm (11ftlb).
- Ensure that the Air Chamber **(56)** is screwed fully into the Handle Base **(46)** so that there are no visible gaps between the parts.

6.1.5 Trigger

- Using the 2mm Pin Punch (07900-00158) drive the Trigger Pin **(36)** out of the Handle Assembly **(33)** and remove the Trigger Button **(6)**.
- Unscrew the Trigger Valve **(35)** using the trigger valve extractor (07900-00692).

7. Troubleshooting Guide

Symptom	Possible Cause	Remedy	Page Ref.
Tool fails to operate	In Line On/Off Valve (7) in 'OFF' position.	In Line On/Off Valve (7) to 'ON' position.	14
	Insufficient air pressure.	Adjust air pressure to within specification.	9
	Damaged Trigger Valve (35).	Replace.	20
Tool does not return fully	Air leak.	Tighten joints or replace components.	
	Low air pressure.	Adjust air pressure to within specification.	9
	Build up of debris inside the Nose Equipment (1.)	Service and clean Nose Assembly (1.)	13, 15
	Stem Collector (3) removed or not fully attached.	Check Stem Collector.	14
More than one operation of the trigger needed to place rivet	Air leak.	Tighten joints or replace components.	
	Low air pressure.	Adjust air pressure to within specification.	9
	Worn or broken Jaws (1h).	Fit new Jaws (1h).	13, 15
	Low oil level or air in oil.	Prime tool.	16
	Build up of debris inside the Nose Equipment (1.)	Service and clean Nose Assembly (1.)	13, 15
	Stem Collector (3) removed or not fully attached.	Check Stem Collector.	14
Tool will not grip stem of rivet	Worn or broken Jaws (1h).	Fit new Jaws (1h).	13, 15
	Build up of debris inside the Nose Equipment (1.)	Service and clean Nose Assembly (1.)	13, 15
	Loose Jaw Guide (1g).	Tighten jaw guide against Pulling Head (1l).	13, 15
	Weak or broken Spring (1k).	Fit new spring (1k).	13, 15
	Incorrect Nose Piece (1a) - (1d) for rivet.	Refer to ProSet Nose Equipment Manual 07900-09414. Select and install correct nose piece	
	Incorrect Nose Equipment (1) for rivet.	Refer to ProSet Nose Equipment Manual 07900-09414. Select and install correct nose equipment	
Jaws will not release broken stem of rivet	Build up of debris inside the Nose Equipment (1.)	Service and clean Nose Assembly (1.)	13, 15
	Jaw Guide (1g), Nose Piece (1a) or Nose Casing (1e) not seated correctly.	Correctly assemble affected parts	13, 15
	Weak or broken Spring (1k).	Fit new spring (1k).	13, 15
	Excess hydraulic oil or air present in oil.	Prime tool.	16
Cannot insert rivet	Incorrect Nose Piece (1a) - (1d) for rivet.	Refer to ProSet Nose Equipment Manual 07900-09414. Select and install correct nose piece	
	Broken rivet stems jammed in Nose Equipment (1.)	Refer to ProSet Nose Equipment Manual 07900-09414.	
		Check Nose Equipment is correct for rivet	
		Service and clean Nose Assembly (1.)	13, 15
	Broken rivet stems jammed in Piston Assembly (19).	Empty Stem Collector (3)	14
Debris in Nose Piece (1a).	Service and clean Nose Assembly (1.)	13, 15	

Symptom	Possible Cause	Remedy	Page Ref.
Slow cycle	Low air pressure.	Adjust air pressure to within specification.	9
	Build up of debris inside the Nose Equipment (1.)	Service and clean Nose Assembly (1.)	13, 15
	Stem Collector (3) removed or not fully attached.	Check Stem Collector.	14
Rivet stem does not break	Low air pressure.	Adjust air pressure to within specification.	9
	Fastener outside tool capability.	Refer to Placing Tool Rivet Range & Nose Equipment table.	11
	Incorrect Nose Equipment (1) for rivet.	Refer to ProSet Nose Equipment Manual 07900-09414. Select and install correct nose equipment	
	Low oil level or air in oil.	Prime tool.	16
Low vacuum	Stem Collector (3) removed or not fully attached.	Check Stem Collector.	14
	Stem Collector (3) full of stems.	Empty Stem Collector (3)	14
	Low air pressure.	Adjust air pressure to within specification.	9

Item numbers in bold refer to assembly drawings and parts lists on pages 2, 4, 5 and 6.

Other symptoms or failures should be reported to your local authorised distributor or repair centre.

8. General Safety Data

8.1 HYPSPIN® VG32 OIL SAFETY DATA

8.1.1 First Aid

SKIN:

Unlikely to cause harm to the skin on brief or occasional contact but prolonged or exposure may lead to dermatitis.

Wash skin thoroughly with soap and water as soon as reasonably practicable. Remove heavily contaminated clothing and wash underlying skin.

Laundry contaminated clothing.

ORAL:

Unlikely to cause harm if accidentally swallowed in small doses, though larger quantities may cause nausea and diarrhea.

If contamination of the mouth occurs, wash out thoroughly with water.

Except as a deliberate act, the ingestion of large amounts of product is unlikely. If it should occur, do not induce vomiting; obtain medical advice.

Take person to nearest medical centre.

EYES:

Unlikely to cause more than transient stinging or redness if accidental eye contact occurs.

Wash eyes thoroughly with copious quantities of water, ensuring eyelids are held open. Obtain medical advice if any pain or redness develops or persists.

8.1.2 Disposal:

Remove all spills with inert absorbent material. Ventilate spill area. Place contaminated materials in a disposable container and dispose in a manner consistent with local regulations.

8.1.3 Protecting the Environment:

Separate collection. This product must not be disposed of with normal waste. Should you find one day that your product needs replacement, or if it is of no further use to you, do not dispose of it with regular waste. Make this product available for separate collection. Separate collection of used products and packaging allows materials to be recycled and used again. Re-use of recycled materials helps prevent environmental pollution and reduces the demand for raw materials. Local regulations may provide for separate collection of electrical products, at municipal waste sites or by the retailer when you purchase a new product. You can check the location of your nearest authorized repair agent by contacting your local STANLEY Engineered Fastening office at the address indicated in this manual. Alternatively, a list of authorized repair agents and full details of our after-sales service and contacts are available on the Internet at: www.StanleyEngineeredFastening.com

8.1.4 Fire:

FLASH POINT: 200°C.

Extinguish with dry, chemical, foam or carbon dioxide. Do not enter confined space without self-contained breathing apparatus.

8.1.5 Handling:

Use barrier cream or oil resistant gloves.

8.1.6 Storage:

Undercover and consistent with local regulations for inflammable material.

8.2 MOLY LITHIUM GREASE EP 3753 SAFETY DATA

8.2.1 First Aid

SKIN:

As the grease is completely water resistant it is best removed with an approved emulsifying skin cleaner.

ORAL:

Ensure the individual drinks 30ml Milk of Magnesia, preferably in a cup of milk.

EYES:

Irritant but not harmful. Irrigate with water and seek medical attention.

8.2.2 Protecting the Environment:

Scrape up for incineration or disposal on approved site.

8.2.3 Fire:

FLASH POINT: Above 220°C.

Not classified as flammable.

Suitable extinguishing media: CO₂, Halon or water spray if applied by an experienced operator.

8.2.4 Handling:

Use barrier cream or oil resistant gloves.

8.2.5 Storage:

Away from heat and oxidizing agent.

8.3 Molykote® 55m Grease Safety Data

8.3.1 First Aid:

SKIN:

Flush with water. Wipe off.

INGESTION:

No first aid should be needed.

EYES:

Flush with water.

8.3.2 Protecting the Environment:

Do not allow large quantities to enter drains or surface waters.

Methods for cleaning up: Scrape up and place in suitable container fitted with a lid. The spilled product produces an extremely slippery surface.

Harmful to aquatic organisms and may cause long-term adverse effects in the aquatic environment. However, due to the physical form and water - insolubility of the product the bioavailability is negligible.

8.3.3 Fire:

FLASH POINT: Above 101.1°C. (closed cup)

Explosive Properties: No

Suitable Extinguishing Media: Carbon Dioxide Foam, Dry Powder or fine water spray.

Water can be used to cool fire exposed containers.

8.3.4 Handling:

General ventilation is recommended. Avoid skin and eye contact.

8.3.5 Storage:

Do not store with oxidizing agents. Keep container closed and store away from water or moisture.

8.4 MOLYKOTE® 111 GREASE SAFETY DATA

8.4.1 First Aid

SKIN:

No first aid should be needed.

ORAL:

No first aid should be needed.

EYES:

No first aid should be needed.

8.4.2 Environment

No adverse effects are predicted.

8.4.3 Fire

FLASH POINT: Above 101.1°C. (closed cup)

Explosive Properties: No

Suitable Extinguishing Media: Carbon Dioxide Foam, Dry Powder or fine water spray.

Water can be used to cool fire exposed containers.

8.4.4 Handling

General ventilation is recommended. Avoid eye contact.

8.4.5 Storage

Do not store with oxidizing agents. Keep container closed and store away from water or moisture.

C.O.S.H.H. data for all hydraulic oils and lubricants is available on request from your tool supplier.



Find your closest STANLEY Engineered Fastening location on
www.stanleyengineeredfastening.com/contact
For an authorized distributor nearby please check
www.stanleyengineeredfastening.com/econtact/distributors

Manual Number	Issue	C/N
7900-09411	B	17/208

© 2017 Stanley Black & Decker, Inc.

Avdel®, Avex®, Avibulb®, Avinox®, Avseal®, Avtainer®, Avdelmate®, Avdelok®, Bulbex®, Hemlok®, Interlock®, Klamp-Tite®, Maxlok®, Monobolt®, POP®, ProSet®, Stavex® and T-Lok® are registered trademarks of Stanley Black & Decker, Inc. and its affiliates.

The names and logos of other companies mentioned herein may be trademarks of their respective owners. Data shown is subject to change without prior notice as a result of continuous product development and improvement policy. Your local STANLEY Engineered Fastening representative is at your disposal should you need to confirm latest information.